

VIVADENS SMART Wall-hung gas condensing boiler





Always the best for you

FRENCH MANUFACTURER
S I N C E 1 6 8 4

De Dietrich 

VIVADENS SMART, experience the best

Smart pillars for your comfort

-  • **Cost-efficient:** save money, extend the service life of your boiler and maximise efficiency thanks to a 10-100% modulation.
-  • **Silent:** enjoy the silent operation of Vivadens Smart which features a compact design and enhanced soundproofing.
-  • **Universal:** can be tailored to your specific needs thanks to a comprehensive range of options, designed to meet to every installation requirement.

-  • **Smart:** control your boiler seamlessly using the E-pilot, an intuitive user interface designed to sync easily with the SMART TC° room thermostat, which connects to Wi-Fi for remote management via a smartphone or tablet.



Compact and discreet

Quality components for reliability and durability

Savings thanks to wide modulation range (up to 1:10)

Easy and quick installation

Smart key quality elements



Vivadens Smart is reliable thanks to its quality components:

- Coupled with proven technology, the high-efficiency **stainless steel boiler heat exchanger** offers easy access to the combustion chamber, ensuring durability and an extended service life.
- The **LIN* bus pump** provides the boiler controller with detailed insights into the hydraulic behaviour of the system, the efficiency and performance of the pump. The LIN bus pump facilitates diagnostics and necessary adjustments to ensure optimal operation.

* Local Interconnect Network is a network protocol used for communication between our smart pump components.



Smart expansion to suit your needs

- Optimize your control system with the built-in Plug & Play function.
- Our Vivadens Smart combined with our pre-wired hydraulic modules ensures maximum functionality within the smallest footprint, making our boiler most discreet and efficient.
- A boiler that will be discreet thanks to its small footprint.

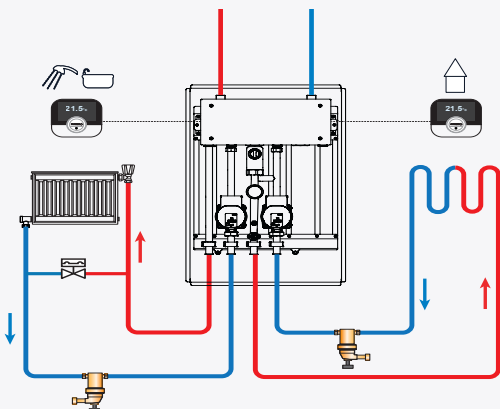

- The **brass hydraulic modules** is equipped with integrated sensors for monitoring the system pressure, the domestic hot water temperature and the flow rate. Whether you have a Combi boiler (with an integrated stainless steel plate-to-plate heat exchanger) or a BIC boiler (with an internal cylinder), or a System boiler with an external cylinder, the module offers a built-in 3-way diverter valve to manage the DHW production.



- A **pressure relief valve** and an automatic air vent ensure safety, long-lasting reliability, and durability, with no additional installation needed outside the boiler.
- The **mounting frame** and **plug-and-play connector** are standard components that we provide, ensuring a fast, reliable and professional installation.



Plug and Play connector

ALEZIO S R32

Think hybrid!



Reduce your CO₂ emissions up to 70% and gain energy independence.

A hybrid system that integrates a boiler and heat pump provides **enhanced performance** and substantial **energy savings**.



Compatible with the SMART TC° intelligent room thermostat

remote heating control for greater comfort and savings



Unlock remote functionality with our **SMART TC°** thermostat and the free **De Dietrich SMART** app:

- Efficiently manage one or **multiple heating zones**.
- Tailor customised operating schedules for your heating system.
- Easily adjust temperature settings and hot water programs.
- Keep track of energy consumption **for optimized usage**.
- Receive real-time alerts directly on your smartphone, to warn you of any operational irregularities.
- Seamlessly integrate with Amazon Alexa or Google Home voice assistants, using the De Dietrich SMART app.



Enhance your installation with the intelligent SMART TC° thermostat using the cloud-based outside temperature, or an external sensor, elevating the seasonal space heating energy efficiency class of your system to A+.

E-Pilot control console

simple and intuitive

- A clear comprehensive text display, in your language
- Easy access to all boiler control parameters
- Electronic pressure control in the installation
- Zone- and error information is available via the main screen
- Compatible with our De Dietrich START and Service Tool apps
- Room thermostat improves overall usage. It allows system monitoring and maintenance. It anticipates and increases the efficiency of the system taking into account the indoor and outdoor temperature.

Control console
E-pilot

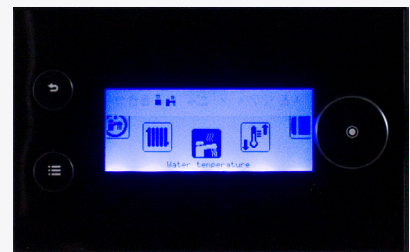

SMART TC°
room thermostat (option)
Can be installed anywhere



Smart solutions to simplify installation work



- Our **Gas Adaptive Control** system (GAC) **ensures enhanced performance** and an improved modulation range. Combustion control offers optimum efficiency even under variable gas and air quality conditions.



- With the optional cloud connected **SMART TC° thermostat**, there is no need to wire a physical outdoor temperature sensor. This **reduces the installation time and related costs**, whilst achieving an Seasonal space heating energy efficiency class for your system of A+.



- The Vivadens Smart **includes a mounting frame** for **seamless and professional installation**.



- The **brass hydroblocks** guarantees **prolonged durability**. De Dietrich has distinguished itself by its high quality for decades, using only top-quality components.



- **E-Pilot intuitive and easy to use interface**. Access all boiler parameters effortlessly with control panel E-Pilot.



- **Multi-zone management** possible thanks to the optional expansion card or a «Plug&Play» pre-equipped solution.



- The Vivadens Smart adjusts its power to meet your comfort needs, providing a stable temperature. With up to 1:10 modulation, it reduces boiler cycles **improving system efficiency and allowing significant energy savings**.

Your heating project

Let us guide you according to your needs



MODELS		24	32	24/29 MI	32/35 MI	24-32/BMR 80	24-32/SRB 130	24/35 BIC
Energy efficiency class				 	 	 	 	
Generator type		Heating only	Heating only	Heating and micro-accumulated DHW	Heating and micro-accumulated DHW	With DHW tank 80L	With DHW tank 130L	Heating and DHW integrated tank 45L
Useful output (Pn) 80/60°C heating mode	kW	24	32	24	32	24/32	24/32	24
Domestic hot water production $\Delta T = 30^\circ C$	L/min	-	-	13,9	16,2	16,5	20	19,2
Net weight	kg	28,5	28,5	28,5	29,2	42,5	60,6	58

Dimensions

VIVADENS SMART

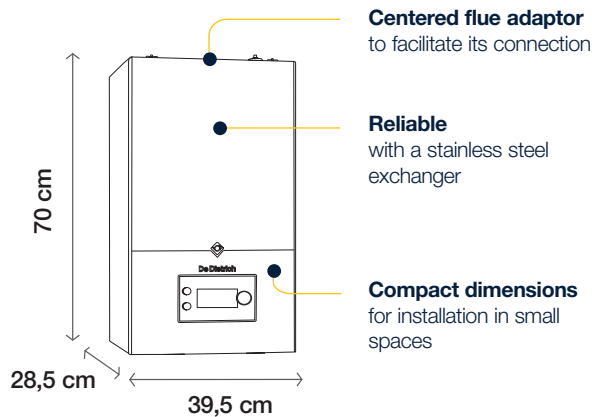

VIVADENS SMART BIC

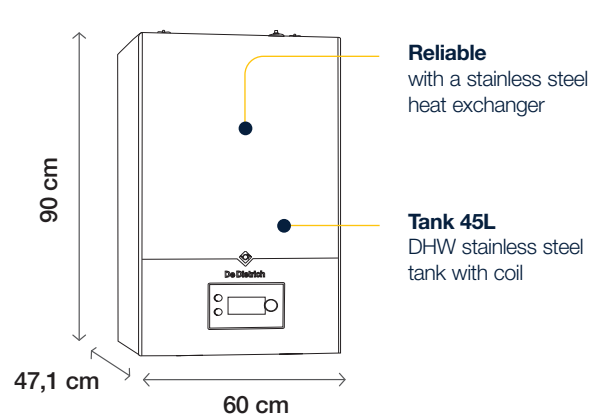

Your installer



BDR THERMEA FRANCE

S.A.S. with corporate capital of 229 288 696 €

57 rue de la Gare - F - 67580 MERTZWILLER
RCS STRASBOURG 833 457 211

www.dedietrich-heating.com

De Dietrich

