

Installation- and maintenance instruction
BENTOFLEX ST108FUV

DESCRIPTION

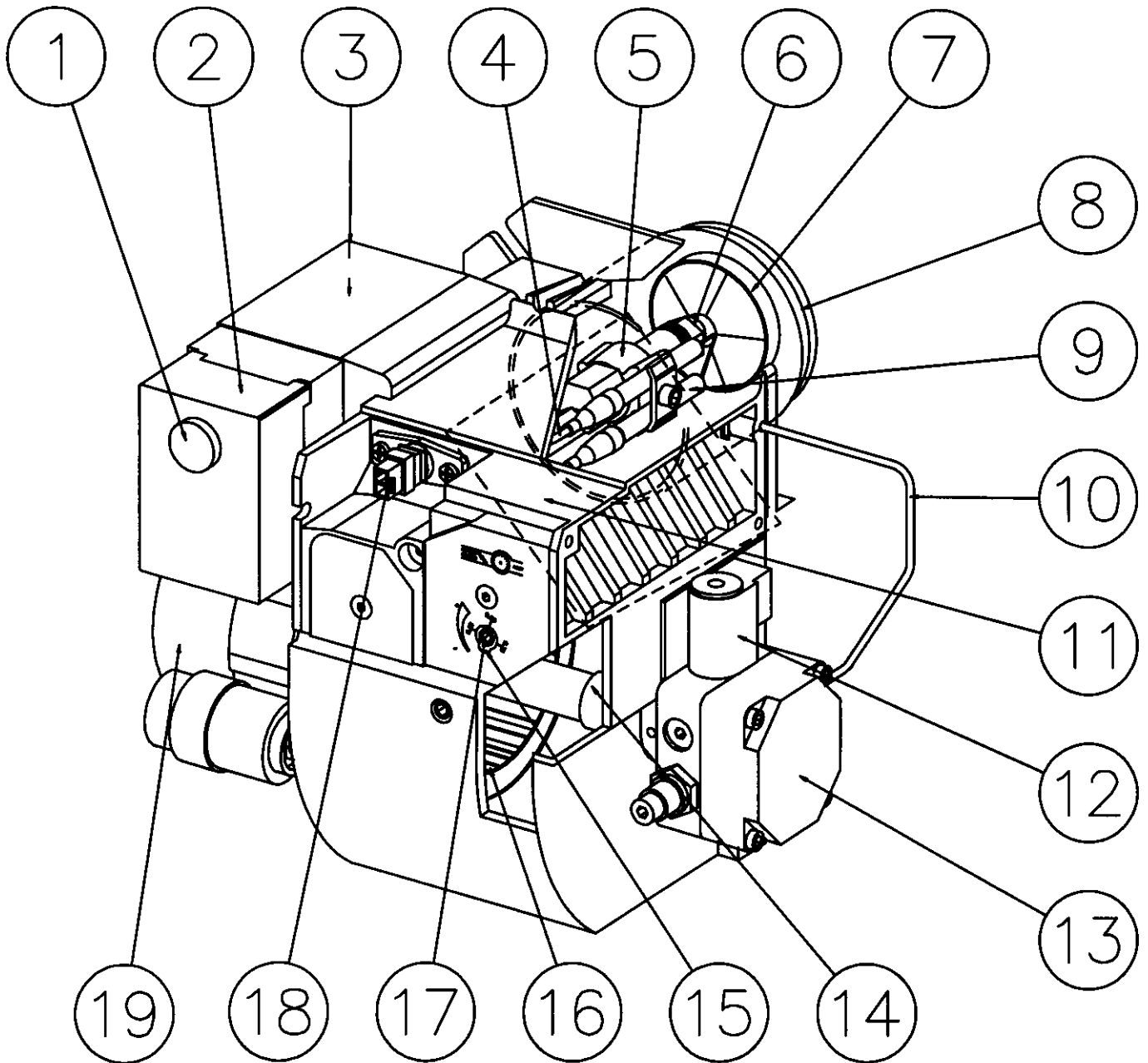

COMPONENTS

- | | | |
|-------------------------|------------------------|----------------------------|
| 1. Reset button | 8. Blast tube | 14. Drive coupling |
| 2. Control box | 9. Ignition electrodes | 15. Indication, air damper |
| 3. Ignition transformer | 10. Connecting pipe | 16. Fan wheel |
| 4. Ignition cables | 11. Air damper | 17. Adjustment, air damper |
| 5. Nozzle assembly | 12. Solenoid valve | 18. Photoresistor |
| 6. Nozzle | 13. Pump | 19. Motor |
| 7. Brake plate | | |

TECHNICAL DATA

ST 108 FUV

DIMENSIONS

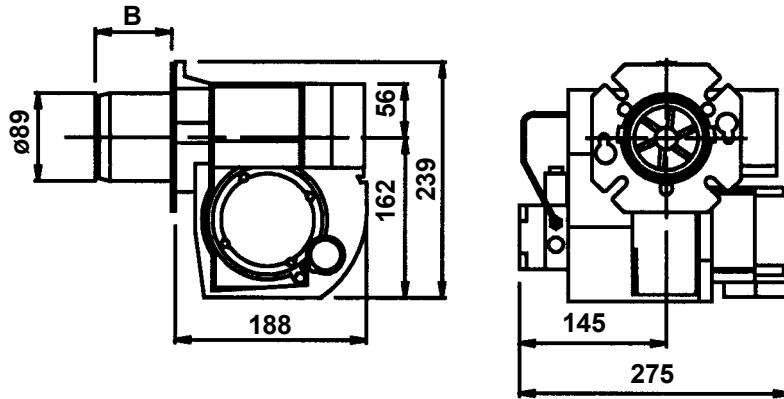

Burner tube	Length of burner tube	Incl. flange A Measure B	Incl. flange B Measure B	Incl. flange C Measure B	Incl. flange D Measure B
FUV	103	68	81	66	65
FUV	133	98	111	119	118

OUTPUT RANGE AND NOZZLES RECOMMENDED

Burner tube	Oil capacity kg/h	Output kW	Output Mcal/h	Recommended nozzle Angle	Recommended nozzle Type	Recommended pump pressure Bar
FUV	1,2-2,9	14-34	12-30	60°, 80°	H, S	10

The net calorific value of 11,86 kWh/kg for light oil has been used.

RECOMMENDED NOZZLE

Because of different boiler types existing on the market, with varying combustion chamber designs, it is not

possible to state a definite spray angle or spray pattern.

Note that the spray angle and the spray pattern change with the pump pressure.

ELECTRODE ADJUSTMENT

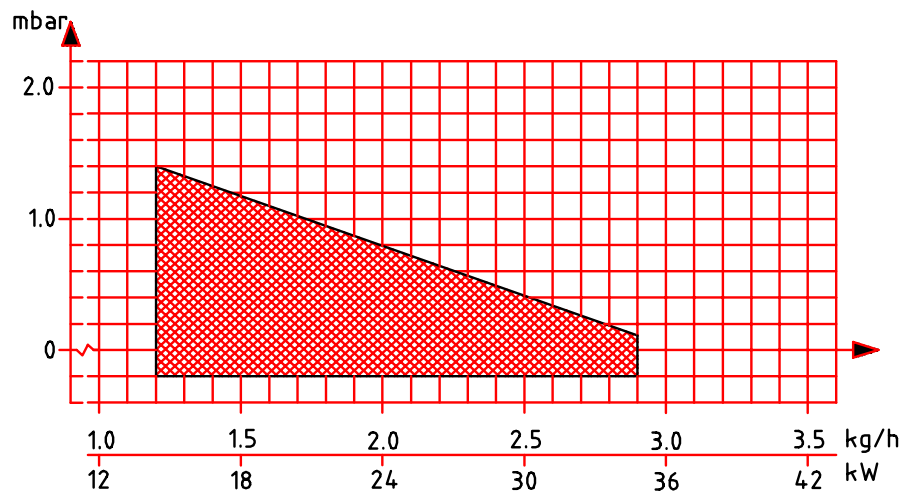
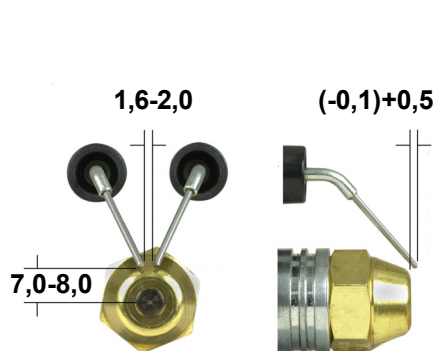

TECHNICAL DATA
DIMENSIONS

Flange A

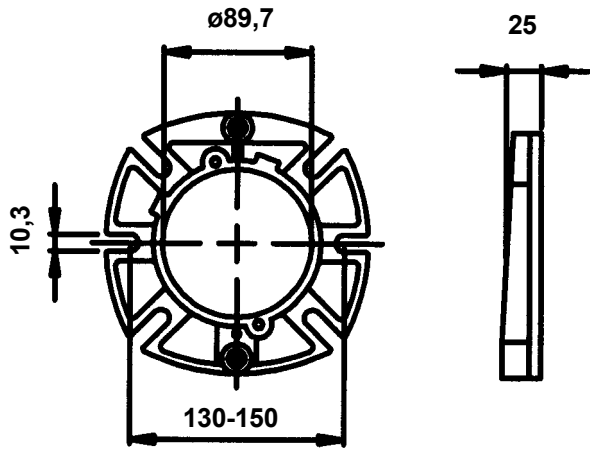

Flange C

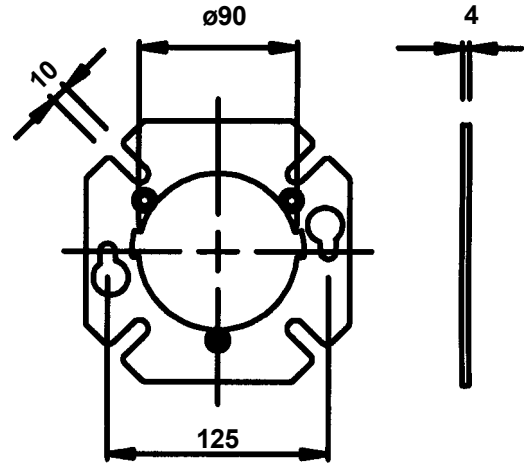

Flange B

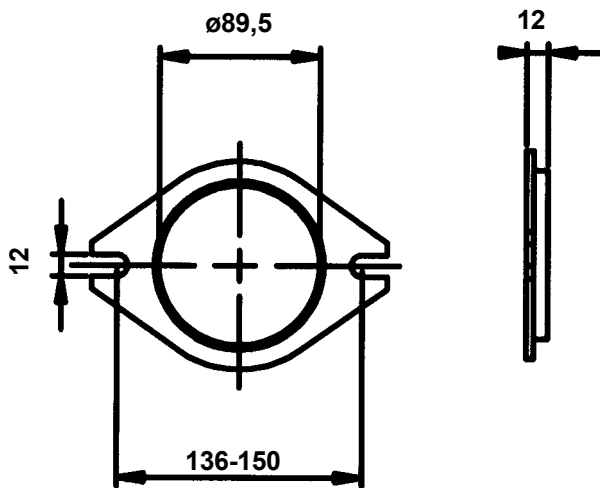

Flange D

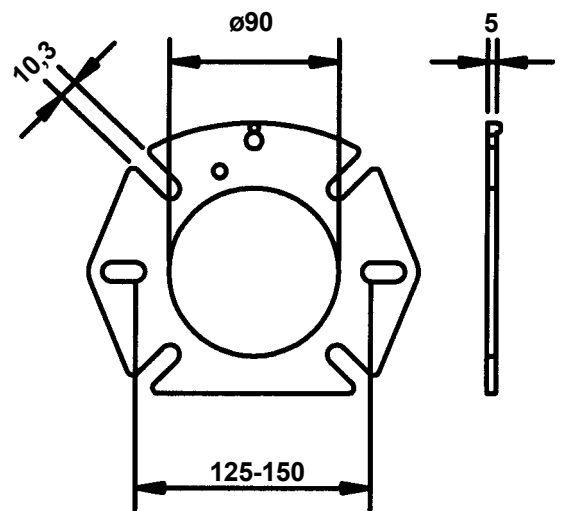

GENERAL INSTRUCTIONS

GENERAL RULES

The installation of an oil burner should be carried out in accordance with local regulations. The installer of the burner must therefore be aware of all regulations relating to oil and combustion.

Only oil suitable for the burner should be used and then in combination with a suitable oil filter before the oil pump of the burner.

If the burner is replacing an existing burner make sure that the oil filter is replaced or cleaned. The installation must only be undertaken by experienced personnel. Care should be taken by the installer to ensure that no electrical cables or fuel/gas pipes are trapped or damaged during installation or service/maintenance.

INSTALLATION INSTRUCTIONS

General installation instructions accompany the burner and should be left in a prominent place adjacent to the burner.

ADJUSTMENT OF BURNER

The burner is from the factory pre-set to an average value that must then be adjusted to the boiler in question.

All burner adjustments must be made in accordance with boiler manufacturers instructions. These must include the checking of flue gas temperatures, average water temperature and CO₂ or O₂ concentration.

To adjust the combustion device, start by increasing the air volume somewhat. When the burner starts it is burning with excess air and smoke number 0. Reduce the air volume until soot occurs and increase again to reach a combustion free of soot.

By this procedure an optimum adjustment is obtained. If larger nozzles are used the preadjustment of the air volume must be increased.

CONDENSATION IN CHIMNEY

A modern burner works with less excess air and often also with smaller nozzles than older models. This increases the efficiency but also the risk of condensation in the chimney. The risk increases if the area of the chimney flue is too large. The temperature of the flue gases should exceed 60°C measured 0,5 metres from the chimney top.

Measures to raise the temperature:
Insulate the chimney in cold attics
Install a tube in the chimney
Install a draught regulator (dilutes the flue gases during operation and dries them up during standstill)
Increase the oil quantity
Raise the flue gas temperature by removing turbulators, if any, in the boiler.

INSTRUCTIONS FOR USE

The end user of the burner should be instructed about the operation and safety features of the burner.

He should also be made aware of the importance of the area around the boiler/burner being kept free of combustible material.

PUMP ADJUSTMENT

See separate description.

ADJUSTMENT OF BURNER

To obtain a correct adjustment a flue gas analysis and a temperature measurement must be carried out. Otherwise there is a risk that a bad adjustment may cause a formation of soot, bad efficiency or condensate in the chimney.

MAINTENANCE

The boiler/burner should be examined regularly for any signs of malfunction or oil leakage.

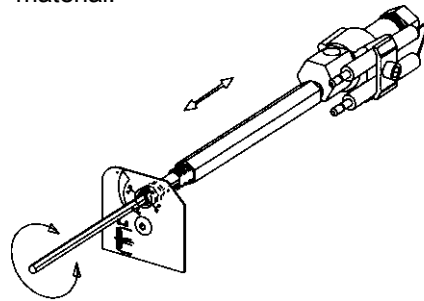

ADJUSTMENT OF NOZZLE
ASSEMBLY 0 - 22

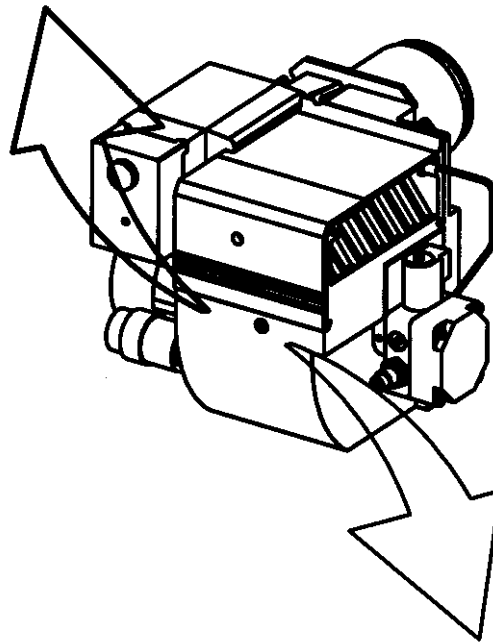

AIR ADJUSTMENT 0 - 32

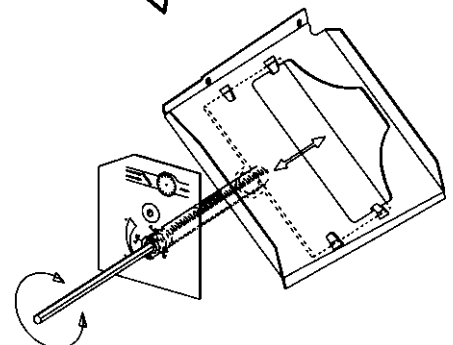

MAINTENANCE OF OIL BURNER

Warning: Before doing any service switch off power at the main switch and cut off the oil supply.

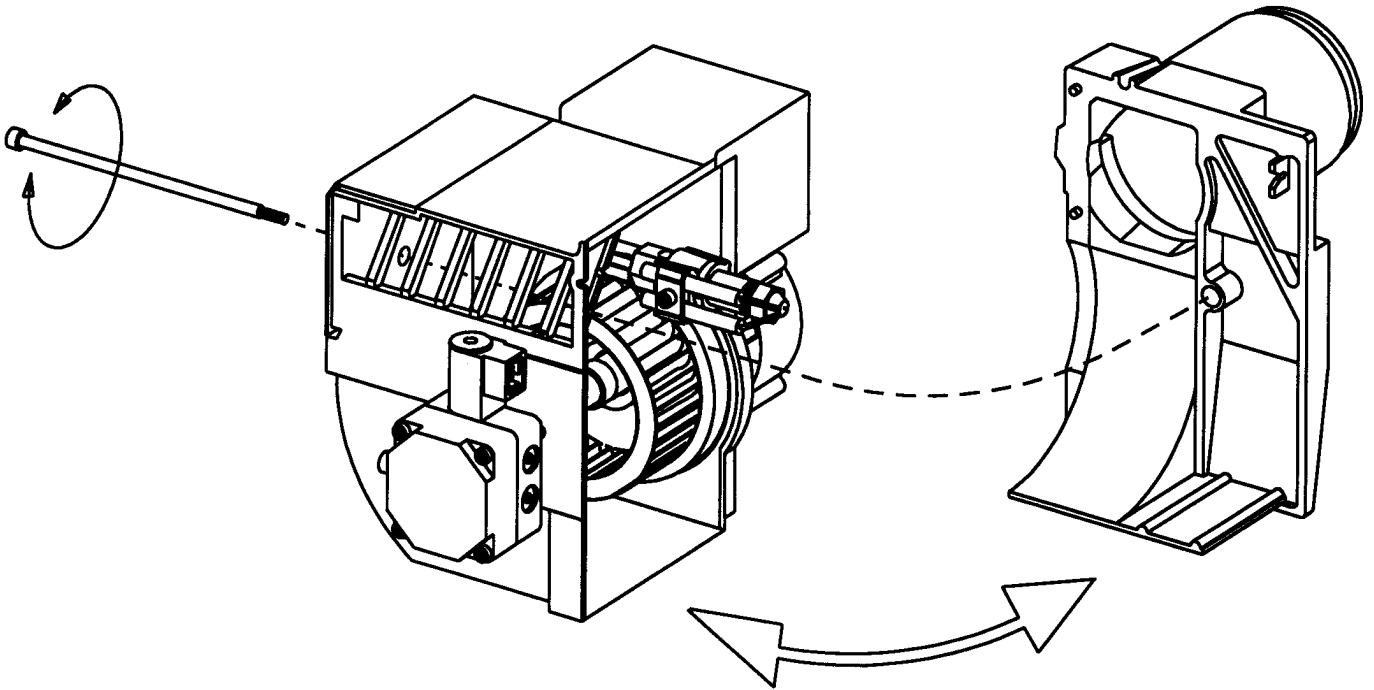

**SERVICE OF BURNER HEAD AND
NOZZLE ASSEMBLY**

ELECTRIC EQUIPMENT

OIL BURNER CONTROL: LOA21.../LOA24...

WITH PREHEATER

FUNCTION

1. Switch on operating switch and twin thermostat
Voltage is applied to the preheater and the preheating period starts. This period lasts till the operating temperature of the oil has been reached and the preheater thermostat closes (2).
 2. Preheater thermostat closes
The burner motor starts, an ignition spark is formed, the prepurge goes on till the prepurge period expires and the solenoid valve opens (3).
 3. Solenoid valve opens
Oil mist is formed and ignited. The photocell indicates a flame.
 - (1) The ignition spark goes out 15 s. after flame indication (**LOA24.171...**).
 - (2) The ignition spark goes out 2 s. after flame indication when the ignition transformer is connected to terminal 7 (**LOA24.173...**).
 4. The safety time expires
 - a. If no flame is established before this time limit the control cuts out.
 - b. If for some reasons the flame disappears after this time limit, the burner will make an attempt to re-start.
 - 4-5. Operating position
If the burner operation is interrupted by means of the main switch or the thermostat, a new start takes place when the conditions in accordance with point 1 are fulfilled.
- The oil burner control cuts out
A red lamp in the control is lit. Press the reset button and the burner re-starts.
- Post-ignition
- (2) If a post-ignition of 15 s. is wanted, move the ignition transformer from terminal 7 to terminal 6 (**LOA24.173...**).

LIST OF COMPONENTS

A1 Oil burner control	P1 Time meter (optional)
A2 Twin thermostat	R1 Photoresistor
E1 Preheater	S3 Main switch
F1 Fuse, max. 10A	T1 Ignition transformer
H1 Alarm lamp	Y1 Solenoid valve
H2 Signal lamp (optional)	X1 Plug-in contact, burner
M1 Burner motor	X2 Plug-in contact, boiler

The colours of the preheater cable: A Blue B Brown C Black
Mains connection and fuses in accordance with local regulations.

TECHNICAL DATA

Pre-ignition time:	13 s
Pre-purge time:	13 s
(1) Post-ignition time:	15 s
(2) Post-ignition time:	2 s
Safety lock-out time:	10 s
Reset time after lockout:	≈ 50 s
Reaction time on flame failure:	max. 1 s
Ambient temperature:	from -20 to +60°C
Min. current with flame established:	65 μA
Max. photo current at start:	5 μA
Enclosure:	IP 40

(Under voltage proof only LOA24...)

CONTROL OF PHOTOCURRENT

Current through photo unit is measured with a d.c. ammeter (a moving coil instrument connected in series with the photo unit).

WIRING DIAGRAM

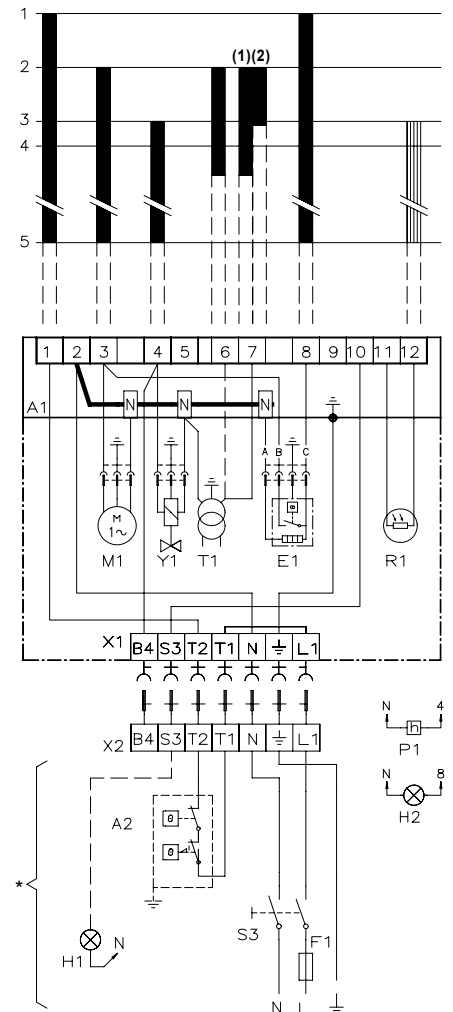

* If there is no plug-in contact (X2) on the boiler, connect to the contact enclosed. In case the twin thermostat is in series on incoming phase L1, a loop between the terminals T1 and T2 is necessary.

OUTER ELECTRICAL CONNECTION

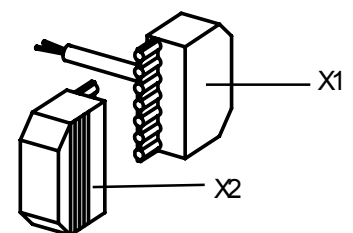

INSTRUCTIONS PUMP TYPE DANFOSS BFP41

TECHNICAL DATA

Viscosity range: 1,3-12,0 mm²/s
 Pressure range: 7-15 bar
 Oil temperature: -10 to +70°C

COMPONENTS

1. Nozzle port G 1/8"
2. Pressure gauge port
3. Pressure adjustment, 4mm allen key
4. Cartridge filter
5. Vacuum gauge port G 1/8"
6. Return line G 1/4"
7. Suction line G 1/4"
8. Return plug

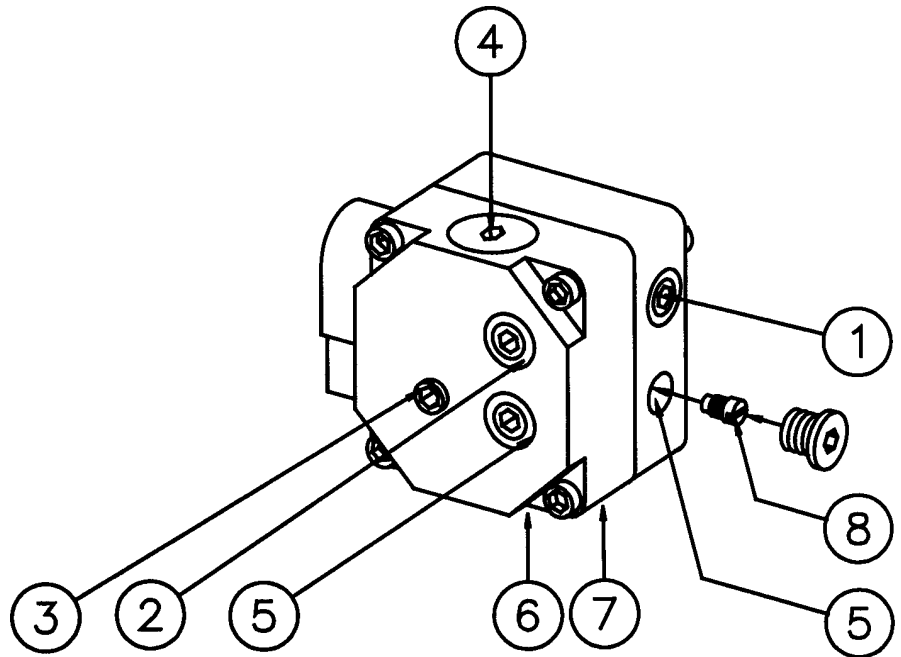

SUCTION LINE TABLES

The suction line tables consist of theoretically calculated values where the pipe dimensions and oil velocity have been matched so that turbulences will not occur. Such turbulences will result in increased pressure losses and in acoustic noise in the pipe system. In addition to drawn copper piping a pipe system usually comprises 4 elbows, a non-return valve, a cut-off valve and an external oil filter.

The sum of these individual resistances is so insignificant that they can be disregarded. The tables do not include any lengths exceeding 100 m as experience shows that longer lengths are not needed.

The tables apply to a standard fuel oil of normal commercial quality according to current standards. On commissioning with an empty tube system the oil pump should not be run without oil for more than 5 min. (a condition is that the pump is being lubricated during operation).

The tables state the total suction line length in metres at a nozzle capacity of 2,5 kg/h. Max. permissible pressure at the suction and pressure side is 2,0 bar.

PURGING

On 1-pipe systems it is necessary to purge the pump. On 2-pipe systems purging is automatic through the return line.

1-pipe system			
Height	Pipe diameter		
H	ø4 mm	ø5 mm	ø6 mm
m	m	m	m
4,0	51	100	100
3,5	45	100	100
3,0	38	94	100
2,5	32	78	100
2,0	26	62	100
1,5	19	47	97
1,0	13	31	65
0,5	6	16	32
Two-pipe system			
Height	Pipe diameter		
H	ø6 mm	ø8 mm	ø10 mm
m	m	m	m
4,0	33	100	100
3,5	31	98	100
3,0	29	91	100
2,5	27	85	100
2,0	25	79	100
1,5	23	72	100
1,0	21	66	100
0,5	19	60	92

1-pipe system			
Height	Pipe diameter		
H	ø4 mm	ø5 mm	ø6 mm
m	m	m	m
4,0	51	100	100
3,5	45	100	100
3,0	38	94	100
2,5	32	78	100
2,0	26	62	100
1,5	19	47	97
1,0	13	31	65
0,5	6	16	32
Two-pipe system			
Height	Pipe diameter		
H	ø6 mm	ø8 mm	ø10 mm
m	m	m	m
4,0	33	100	100
3,5	31	98	100
3,0	29	91	100
2,5	27	85	100
2,0	25	79	100
1,5	23	72	100
1,0	21	66	100
0,5	19	60	92
0	17	53	100
-0,5	15	47	100
-1,0	13	41	99
-1,5	11	34	84
-2,0	9	28	68
-2,5	7	22	53
-3,0	5	15	37
-3,5	3	9	22
4,0	1	3	6

With an underlying tank a 1-pipe-system is not recommended

FUNCTION DANFOSS BFP41

When the oil pump is started, oil is drawn from the suction connection (S) through the filter (H) to the suction side of the gear wheel (C).

The gear wheel then pumps oil to the pressure side and the oil is put under pressure.

The pressure is controlled and kept constant at the set value by the regulating valve (P₁) with the diaphragm (D).

The regulating valve (P₁) distributes the oil quantity supplied by the gear set (C) between the nozzle port (E) and the return side of the pump (R).

The oil quantity utilized is determined by the set pressure on the regulating valve (P₁) and the size of the oil nozzle in the nozzle line.

The valve (P₁) functions in the following way:

- When the opening pressure has been reached, the passage to the return side opens.
- The diaphragm and the spring keep the pump pressure constant at set value.
- If the pump is overloaded, i.e. if you try to get out more oil than the gear

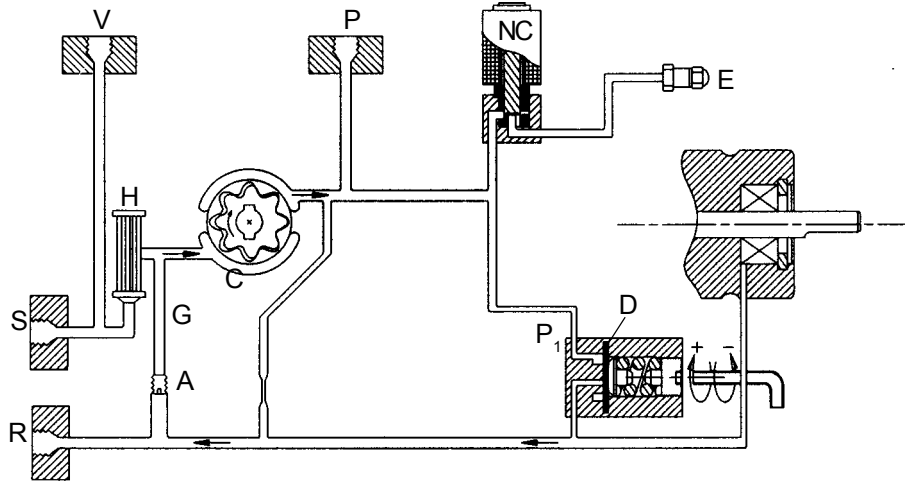

set can supply under existing circumstances, the oil pressure falls below the set value and the valve closes against the return side (R) by means of the diaphragm (D) and goes into starting position.

This can be remedied by:

- Reducing the pump pressure.
- Reducing the oil quantity supplied by using a smaller nozzle.
- Using a pump with a larger capacity.

BURNER WITH PREHEATING

Consider that the oil quantity is reduced at preheating by 5-20% depending on.

- Rise in temperature at the nozzle
- Nozzle design
- Capacity (high capacity - small difference)

HOW TO REMOVE CARTRIDGE FILTER FROM PLUG

Unscrew the cartridge filter plug in the cover by means of a 4 mm allen key and withdraw the cartridge filter. If necessary, put a screwdriver between the cartridge filter and the plug and turn the cartridge filter carefully until it comes off. Reject the cartridge filter and replace it by a new one. Press it on to the plug. Ensure that the O-ring is not damaged. Then fit the new cartridge filter to the pump.

REPLACEMENT OF CARTRIDGE FILTER

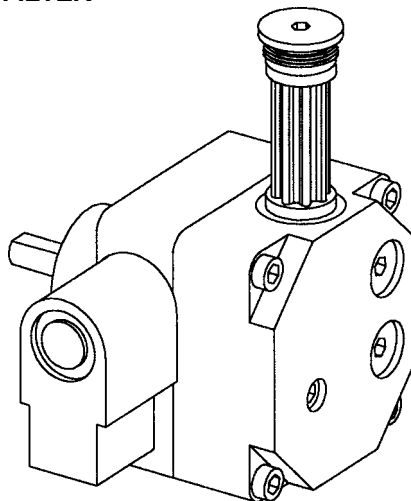

MOUNTING/DISMOUNTING RETURN PLUG

One pipe system

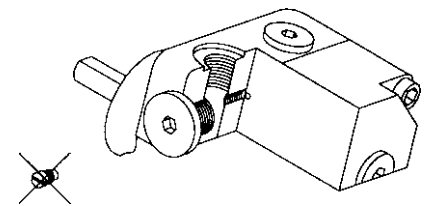

Two pipe system

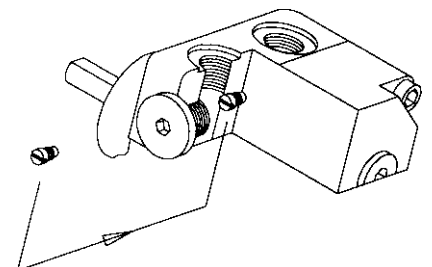

NOZZLE TABLE

Pump pressure bar

Gph	8			9			10			11			12			13			14			15		
	kg/h	kW	Mcal/h	kg/h	kW	Mcal/h	kg/h	kW	Mcal/h	kg/h	kW	Mcal/h	kg/h	kW	Mcal/h	kg/h	kW	Mcal/h	kg/h	kW	Mcal/h	kg/h	kW	Mcal/h
0,40	1,33	16	13	1,41	17	14	1,49	18	15	1,56	18	16	1,63	19	17	1,70	20	17	1,76	21	18	1,82	21	18
0,50	1,66	20	17	1,76	21	18	1,86	22	19	1,95	23	20	2,04	24	21	2,12	25	22	2,20	26	22	2,28	27	23
0,60	2,00	24	20	2,12	25	22	2,23	26	23	2,34	28	24	2,45	29	25	2,55	30	26	2,64	31	27	2,73	32	28
0,65	2,16	26	22	2,29	27	23	2,42	29	25	2,54	30	26	2,65	31	27	2,75	33	28	2,86	34	29	2,96	35	30
0,75	2,49	29	25	2,65	31	27	2,79	33	28	2,93	35	30	3,08	36	31	3,18	38	32	3,30	39	34	3,42	40	35
0,85	2,83	33	29	3,00	36	31	3,16	37	32	3,32	39	34	3,47	41	35	3,61	43	37	3,74	44	38	3,87	46	39
1,00	3,33	39	34	3,53	42	36	3,72	44	38	3,90	46	40	4,08	48	42	4,24	50	43	4,40	52	45	4,56	54	46
1,10	3,66	43	37	3,88	46	39	4,09	48	42	4,29	51	44	4,48	53	46	4,67	55	48	4,84	57	49	5,01	59	51
1,20	3,99	47	41	4,24	50	43	4,47	53	46	4,68	55	48	4,89	58	50	5,09	60	52	5,29	63	54	5,47	65	56
1,25	4,16	49	42	4,40	52	45	4,65	55	47	4,88	58	50	5,10	60	52	5,30	63	54	5,51	65	56	5,70	68	58
1,35	4,49	53	46	4,76	56	48	5,02	59	51	5,27	62	54	5,50	65	56	5,73	68	58	5,95	70	61	6,15	73	63
1,50	4,98	59	51	5,29	63	54	5,58	66	57	5,85	69	60	6,11	72	62	6,36	75	65	6,60	78	67	6,83	81	70
1,65	5,49	65	56	5,82	69	59	6,14	73	63	6,44	76	66	6,73	80	69	7,00	83	71	7,27	86	74	7,52	89	77
1,75	5,82	69	59	6,18	73	63	6,51	77	66	6,83	81	70	7,14	85	73	7,42	88	76	7,71	91	79	7,97	94	81
2,00	6,65	79	68	7,06	84	72	7,45	88	76	7,81	93	80	8,18	97	83	8,49	101	86	8,81	104	90	9,12	108	93
2,25	7,49	89	76	7,94	94	81	8,38	99	85	8,78	104	89	9,18	109	94	9,55	113	97	9,91	117	101	10,26	122	105
2,50	8,32	99	85	8,82	105	90	9,31	110	95	9,76	116	99	10,19	121	104	10,61	126	108	11,01	130	112	11,39	135	116
2,75	9,15	108	93	9,71	115	99	10,24	121	104	10,73	127	109	11,21	133	114	11,67	138	119	12,11	144	123	12,53	148	128
3,00	9,98	118	102	10,59	126	108	11,16	132	114	11,71	139	119	12,23	145	125	12,73	151	130	13,21	157	135	13,67	162	139
3,50	11,65	138	119	12,35	146	126	13,03	154	133	13,66	162	139	14,27	169	145	14,85	176	151	15,42	183	157	15,95	189	163
4,00	13,31	158	136	14,12	167	144	14,89	176	152	15,62	185	159	16,31	193	166	16,97	201	173	17,62	209	180	18,23	216	186
4,50	14,97	177	153	15,88	188	162	16,75	198	171	17,57	208	179	18,35	217	187	19,10	226	195	19,82	235	202	20,51	243	209
5,00	16,64	197	170	17,65	209	180	18,62	221	190	19,52	231	199	20,39	242	208	21,22	251	216	22,03	261	225	22,79	270	232
5,50	18,30	217	187	19,42	230	198	20,48	243	209	21,47	255	219	22,43	266	229	23,34	277	238	24,23	287	247	25,07	297	256
6,00	19,97	237	204	21,18	251	216	22,34	265	228	23,42	278	239	24,47	290	249	25,46	302	260	26,43	313	269	27,49	326	280
6,50	21,63	256	220	22,94	272	234	24,20	287	247	25,37	301	259	26,51	314	270	27,58	327	281	28,63	339	292	29,63	351	302
7,00	23,29	276	237	24,71	293	252	26,06	309	266	27,33	324	279	28,55	338	291	29,70	352	303	30,84	366	314	31,91	378	325
7,50	24,96	296	254	26,47	314	270	27,92	331	285	29,28	347	298	30,59	363	312	31,83	377	324	33,04	392	337	34,19	405	349
8,00	26,62	316	271	28,24	335	288	29,79	353	304	31,23	370	318	32,63	387	333	33,95	403	346	35,25	418	359	36,47	432	372
8,50	28,28	335	288	30,00	356	306	31,65	375	323	33,18	393	338	34,66	411	353	36,07	428	368	37,45	444	382	38,74	459	395
9,00	29,95	355	305	31,77	377	324	33,59	398	342	35,14	417	358	36,71	435	374	38,19	453	389	39,65	470	404	41,02	486	418

 The table applies to oil with a viscosity of 4,4 mm²/s (cSt) with density 830 kg/m³.

BURNER WITH PREHEATER

Consider that on preheating the oil quantity is reduced by 5-20% depending on.

- Rise in temperature at the nozzle
- Design of nozzle
- Capacity (high capacity - small difference)

FAULT LOCATION

BURNER FAILS TO START

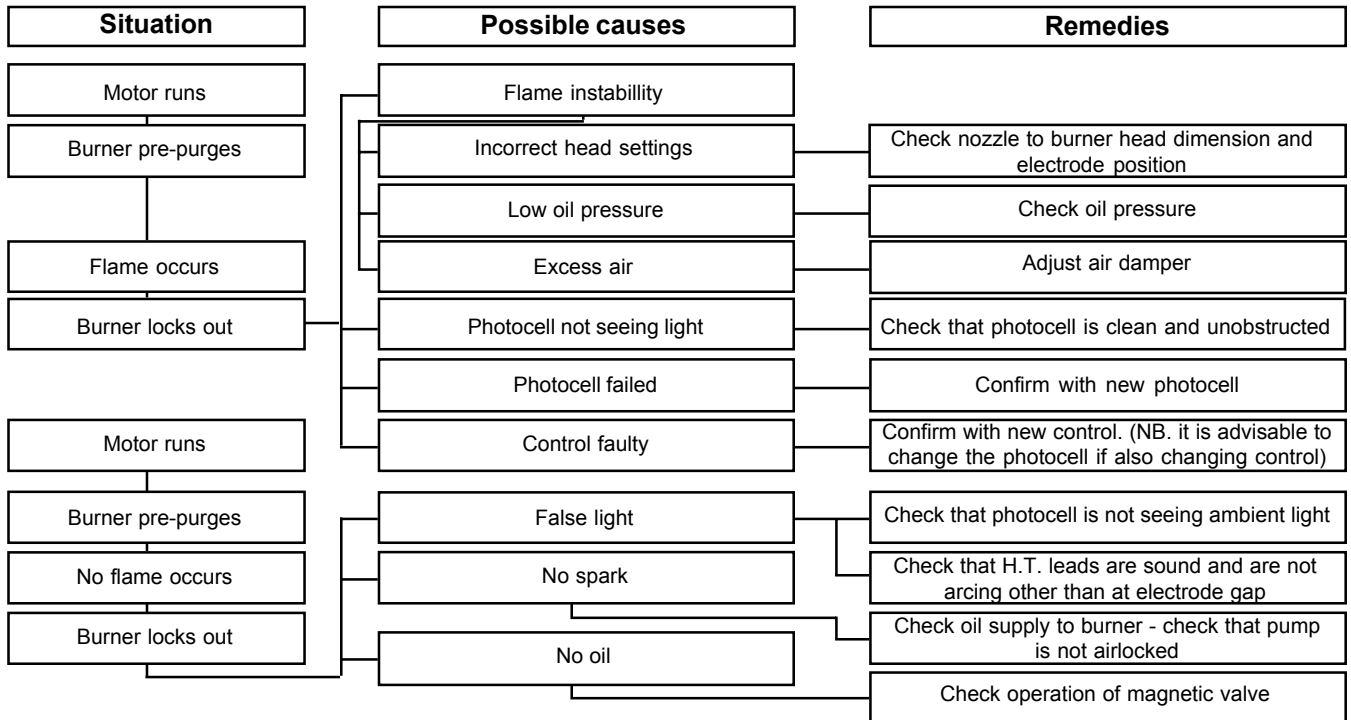

BURNER FAILS TO START AFTER NORMAL OPERATION

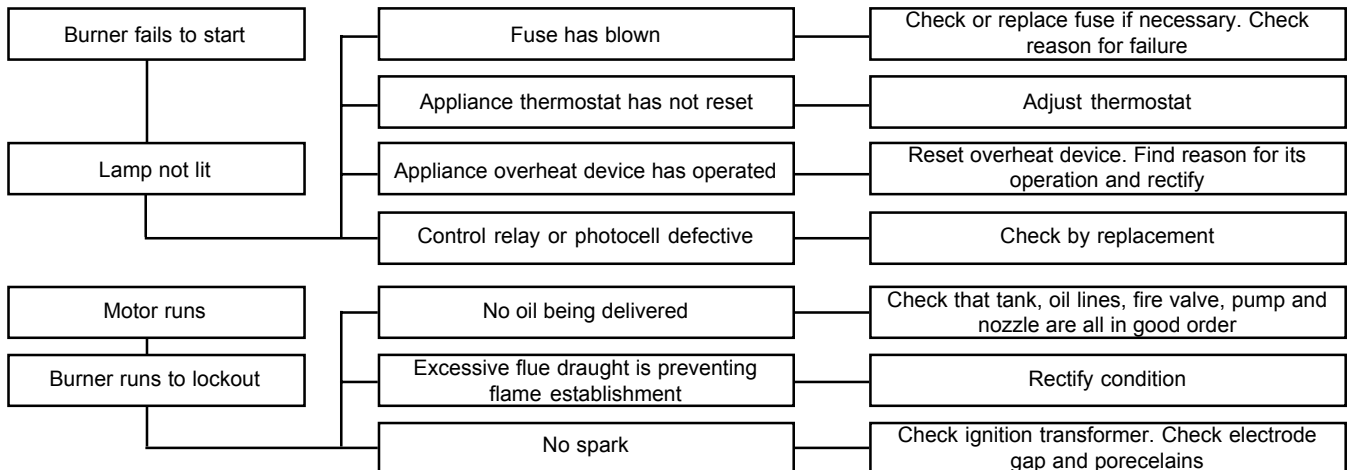

DELAYED IGNITION, BURNERS STARTS VIOLENTLY

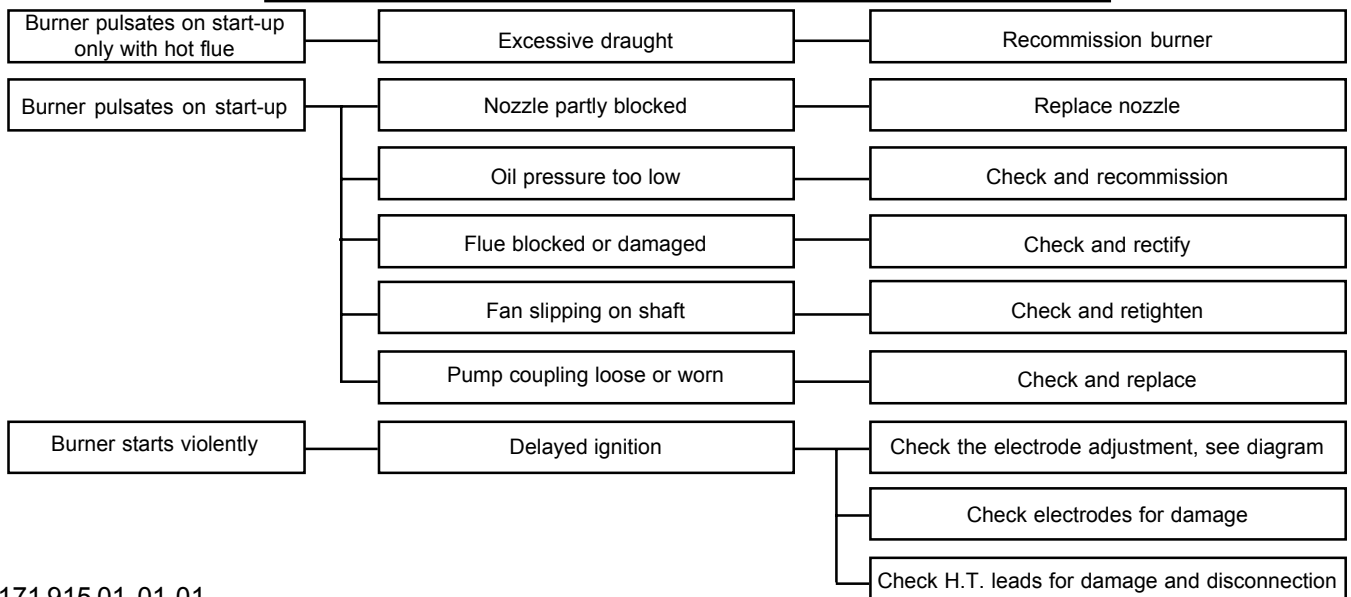

DECLARATION OF CONFORMITY

We
(supplier's name)

BENTONE

(address)

P.O. Box 309, S-341 26 Ljungby, Sverige

declare under our sole responsibility that the product
(name, type or model, batch or serial number, possibly sources and number of items)

ST 97, ST 108, ST 120, ST 133, ST 146, B 9, B 10, B 11, B 20, B 30, B 40, B 45, B 50, B 60, B 70, B 80,

fan burners for gasoil

to which this declaration relates is in conformity with the following standard(s) or the normative document(s)
(title and/or number and date of issue of the standard(s) or other normative document(s))

EN 267

following the provisions of Directive
(if applicable)

EMC directive 89 / 336 / EEC, Low voltage directive 73 / 23 / EEC and Machinery directive 89/392/EEC.

Re. the Efficiency directive 92/42/EEC, please see the next page.

Ljungby 28 - 1 2003

(Place and date of issue)

BENTONE
Ulf Bondeson

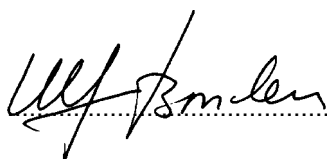

(name and signature of equivalent marking of authorized person)

To fulfil the demands according to the Efficiency directive 92/42/EEC, Article 2, we herewith state the following parameters.

Burner type	Capacity kg/h (kW)	Test report No. TÜV	Pressure in combustion chamber mbar	Product ID-No. as per EC-Type Examination Certificate
ST 97	1,2-2,6 (14,2-30,8)	3728 (15.03.96)	-0,2 to+1,4 to + 0,1	CE 0036 0128/98
ST 108	1,2-3,8 (14,2-45)	3729 (15.03.96)	-0,2 to + 1,4 to + 0,2	CE 0036 0129/98
ST 120	2,1-4,5 (24,9-53,3)	3581 (10.11.94)	-0,2 to + 1,9 to + 0,2	CE 0036 0130/98
ST 133	2,0-10,0 (23,7-118,5)	3795 (12.11.96)	-0,2 to + 2,2 to + 0,1	CE 0036 0131/98
ST 146	4,0-10,0 (47,4-118,5)	3796 (12.11.96)	-0,2 to + 3,9 to + 0,1	CE 0036 0132/98
B 9	1,2-2,5 (14,2-29,6)	3341 (21.08.92)	-0,2 to + 0,8 to + 0,1	CE 0036 0133/98
B 10	1,4-3,0 (16,6-35,6)	3465 (03.09.93)	-0,2 to + 1,1 to + 0,25	CE 0036 0134/98
B 10KA	2,0-4,6 (23,7-54,5)	3778 (18.10.96)	-0,2 to + 0,95 to + 0,1	CE 0036 0135/98
B 10ZHV	1,2-2,5 (14,2-29,5)	3525 (21.01.94)	-0,2 to + 1,0 to + 0,3	CE 0036 0136/98
B 11				
B 20K	4,3-9,8 (51,0-116,1)	3779 (18.10.96)	-0,2 to + 1,15 to + 0,1	CE 0036 0137/98
B 20KA	2,0-8,0 (23,7-94,8)	3333 (04.08.92)	-0,2 to 0,78 to + 0,1	CE 0036 0138/98
B 20ZHV	2,1-4,3 (24,9-51,0)	3397 (14-06.93)	-0,2 to 1,25 to + 0,1	CE 0036 0139/98
B 30	6,0-17,5 (71,1-207,4)	3524 (24.01.94)	-0,2 to + 2,8 to + 0,2	CE 0036 0140/98
B 30A	6,0-17,0 (71,1-207,4)	3797 (12.11.96)	-0,2 to + 3,0 to + 0,1	CE 0036 0141/98
B 30A2	4,5-15,0 (53,3-177,8)	3798 (12.11.96)	-0,2 to 3,8 to + 0,1	CE 0036 0142/98
B 30ZHV-2	3,3-10,0 (39,1-118,5)	3563 (10.11.94)	-0,2 to + 1,3 to + 0,1	CE 0036 0143/98
B 40	9,0-29,5 (106,7-349,6)	3503 (21.09.93)	-0,3 to + 4,1 to + 0,2	CE 0036 0144/98
B 40A	9,0-29,5 (106,7-349,6)	3799 (12.11.96)	-0,2 to + 5,3 to + 0,1	CE 0036 0145/98

To fulfil the demands according to the Efficiency directive 92/42/EEC, Article 2, we herewith state the following parameters.

Burner type	Capacity kg/h (kW)	Test report No. TÜV	Pressure in combustion chamber mbar	Product ID-No. as per EC-Type Examination Certificate
B 50-2F	12,0-59,0 (142,2-699,2)	3390 (09.06.93)	-0,2 to +9,4 to + 0,2	CE 0036 0147/98
B 50-3F	12,0-59,0 (142,2-699,2)	3592 (10.11.94)	-0,2 to + 9,25 to + 0,1	CE 0036 0148/98
B 60-2F	20,0-90,0 (237,0-1066,5)	3466 (03.09.93)	-0,3 to + 11,4 to + 0,8	CE 0036 0149/98
B 60-3F	20,0-90,0 (237,0-1066,5)	3591 (10.11.94)	-0,3 to + 11,4 to + 0,8	CE 0036 0150/98
B 70				
B 80				
SF 141-3	50,0-140,0 (592,5-1659,0)	3502 (16.09.93)	-0,7 to 8,7 to + 12,0 to + 0,1	CE 0036 0151/98
TF 205-3	70,0-205,0	3501 (16.09.93)	-0,7 to + 14,0 to + 16,0 to + 0,1	CE 0036 0152/98
B45A	8,5-47,0 (100,8-557,5)	3977 (16.04.99)	-0,1 to + 0,4 to + 7,0	CE 0036 0250/99
B45A2	8,5-45,5 (100,8-539,7)	3978 (16.04.99)	-0,1 to + 0,4 to + 7,5	CE 0036 0251/99