

Installation- and maintenance instruction

BG450M

DESCRIPTION

Warning



- Read the manual before assembling or commissioning.
- The contents of this manual are to be observed by all who work for any reason on the unit and its appertaining system parts.
- This manual is intended especially for authorised personnel.
- This manual is to be regarded as part of the burner and shall always be available near the place of installation.
- The burner is only to be installed by qualified personnel
- Check that the burner is suitable for the boiler's power range.
- The burner is to be installed such that it complies with any local regulations relating to electrical safety, boilers and fuel distribution.
- Check that the burner is approved for the gas quality intended used.
- No burner safety systems are to be disengaged.
- The fitter is to ensure that the boiler room is supplied with fresh air ventilation that is sufficient in accordance with local standards.
- Before servicing, shut off the fuel supply and the power supply to the burner.
- The outer temperature of the boiler's components can exceed 60 °C.
- Check that the guide stop is installed before servicing.
- Take great care when servicing. Trap and pinch risks can be present.
- The boiler's sound level can exceed 85 dBA during operation. Use ear protectors when present in the boiler room

Safety directions

- The electrical installation shall be made according to valid regulations for heavy current and in a professional way, so that the risk of leaking gas, fire or personal injury is avoided.
- If another electrical connection is used than the one recommended by Enertech, there might be a risk of material damage or personal injury.
- Notice should be carefully taken by the installer that no electrical cables or gas pipes get squeezed or damaged when installing or at service
- If the boiler is provided with an opening door, this should be interlocked with a door switch.

Acceptance inspection

- Ensure that everything is delivered and that there is no transport damage.
- If there is anything wrong with the delivery, please report it to the supplier.
- Any transport damage should be reported to the forwarding company.

Preparations for installation

- Ensure that the size and capacity range of the burner are suitable for the boiler.
- Power data on the data plate refer to the minimum and maximum power of the burner.

DESCRIPTION

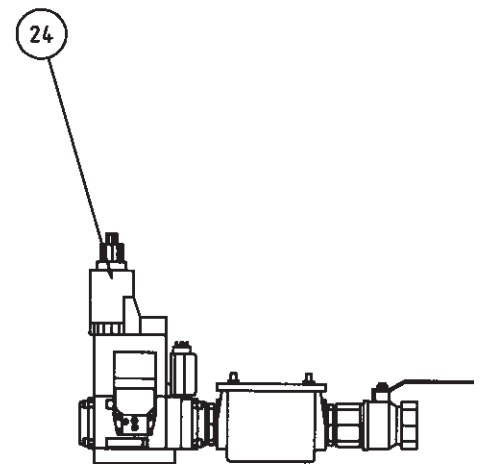
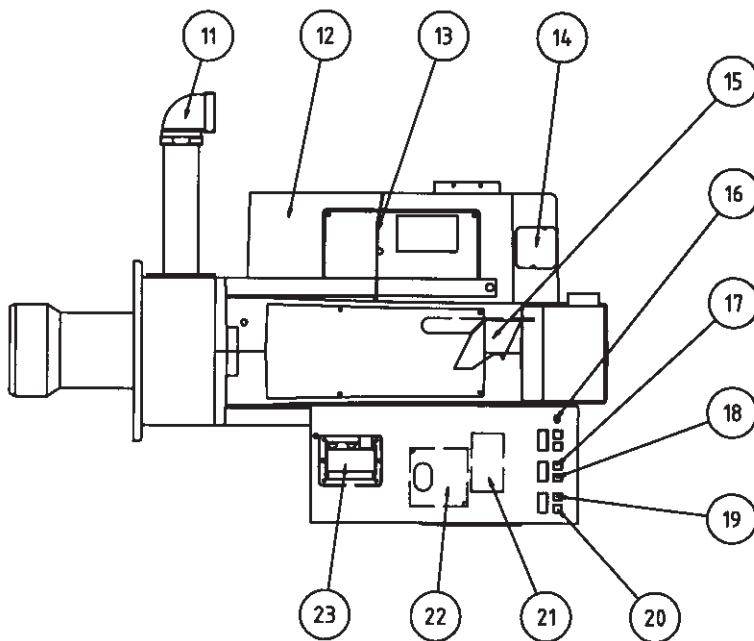
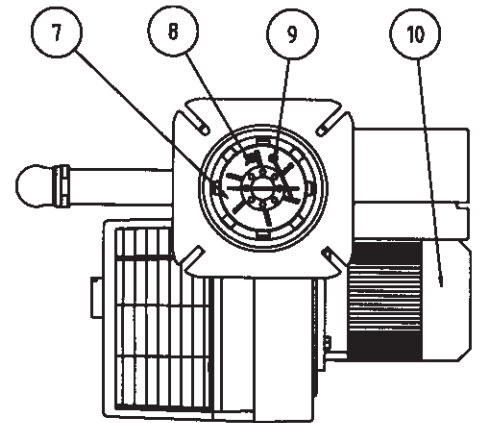
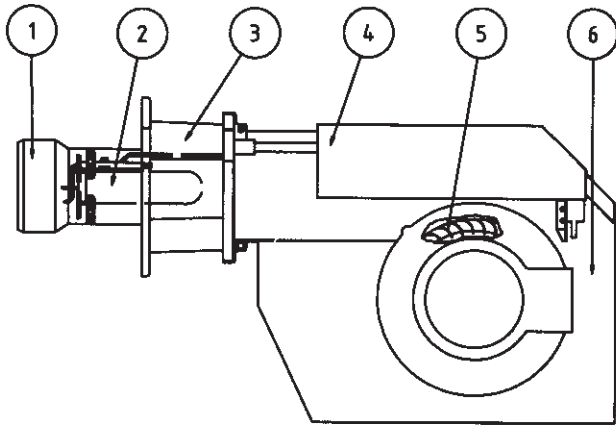

Components

- | | | |
|-------------------------|--|--|
| 1. Flame cone | 11. Connection gas fittings | 18. Switch I-II
(For modulating burner:
Change-over switch manually-
automatically) |
| 2. Inner assembly | 12. Air intake | 19. Indicating lamp Stage 1 |
| 3. Fixing flange | 13. Air damper | 20. Switch 0-1 |
| 4. Electric panel | 14. Air pressure switch | 21. Contactor |
| 5. Fan wheel | 15. Conical shield plate | 22. Control box |
| 6. Fan house | 16. Fuse | 23. Ignition transformer |
| 7. Shrouded disc | 17. Indicating lamp Stage 2
(For modulating burner: Change-
over switch increase-decrease) | 24. MultiBloc |
| 8. Ignition electrode | | |
| 9. Ionisation electrode | | |
| 10. Motor | | |

TECHNICAL DATA

Type designation BG 450

Dimensions

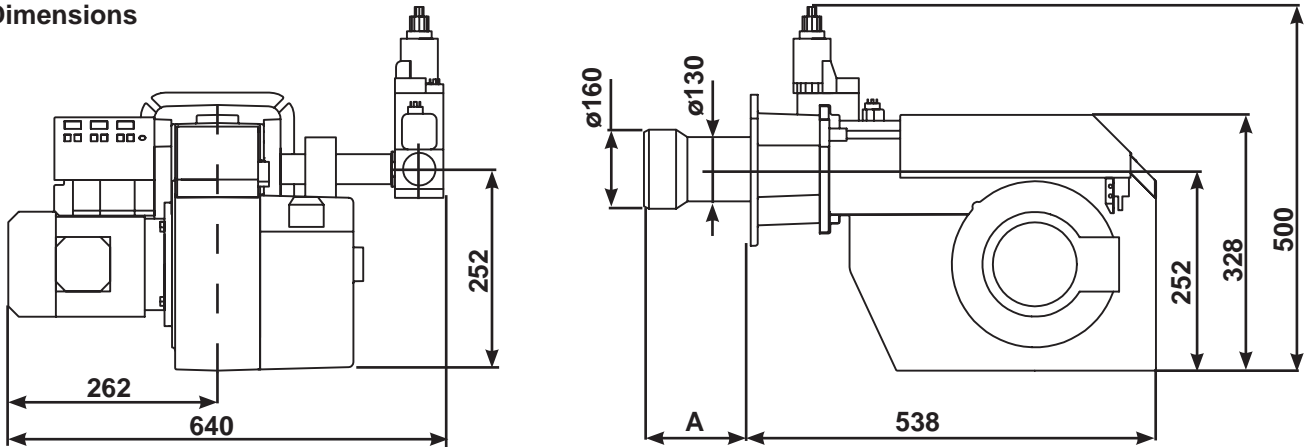

	Length of burner tube	Flange Measure A
Standard	256	226
Long design	356	326

The above dimensions are max. measurements. Depending on the components used, the measurements may vary.

Out range

Type	Capacity kW	Gas volume at a min. output Nm ³ /h ¹⁾		Gas volume at a max output Nm ³ /h ¹⁾		Max. inlet pressure mbar	Rated inlet pressure mbar	
450	Natural gas/LPG 120-550 ²⁾ Town gas	Natural gas 12 ²⁾ Town gas	LPG 4,6 ²⁾ Town gas	Natural gas 55 ²⁾ Town gas	LPG 21 ²⁾ Town gas	360	Natural gas 40 ²⁾ Town gas	LPG 30-50 ²⁾ Town gas

Armatür ²⁾	Motor	Ignition transformer
Natural gas LPG 1 1/2" ²⁾ Town gas	1-fas, 450W, 2 800 r/m, 230/240 V	Primary 230 V, 1 A Secondary 8 000 V

¹⁾ Calorific value:
Natural gas 10 kWh/Nm³
LPG 26 kWh/Nm³

²⁾ Dimension and capacity depending on gas quality and available inlet pressure

CAPACITY CHART ACCORDING TO EN 676

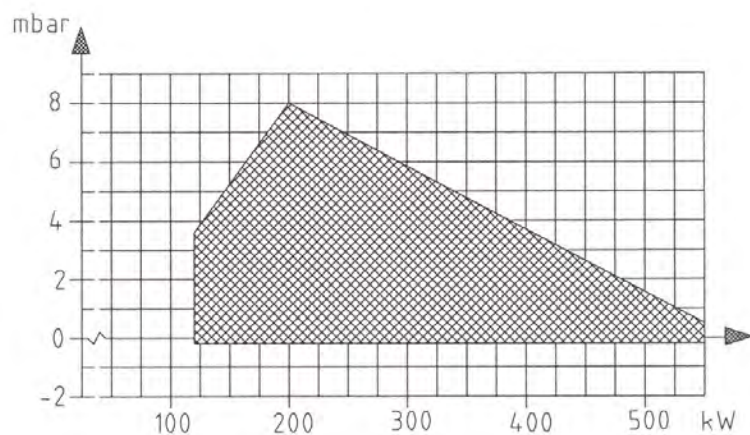

TECHNICAL DATA

DIMENSIONS OF FLANGE

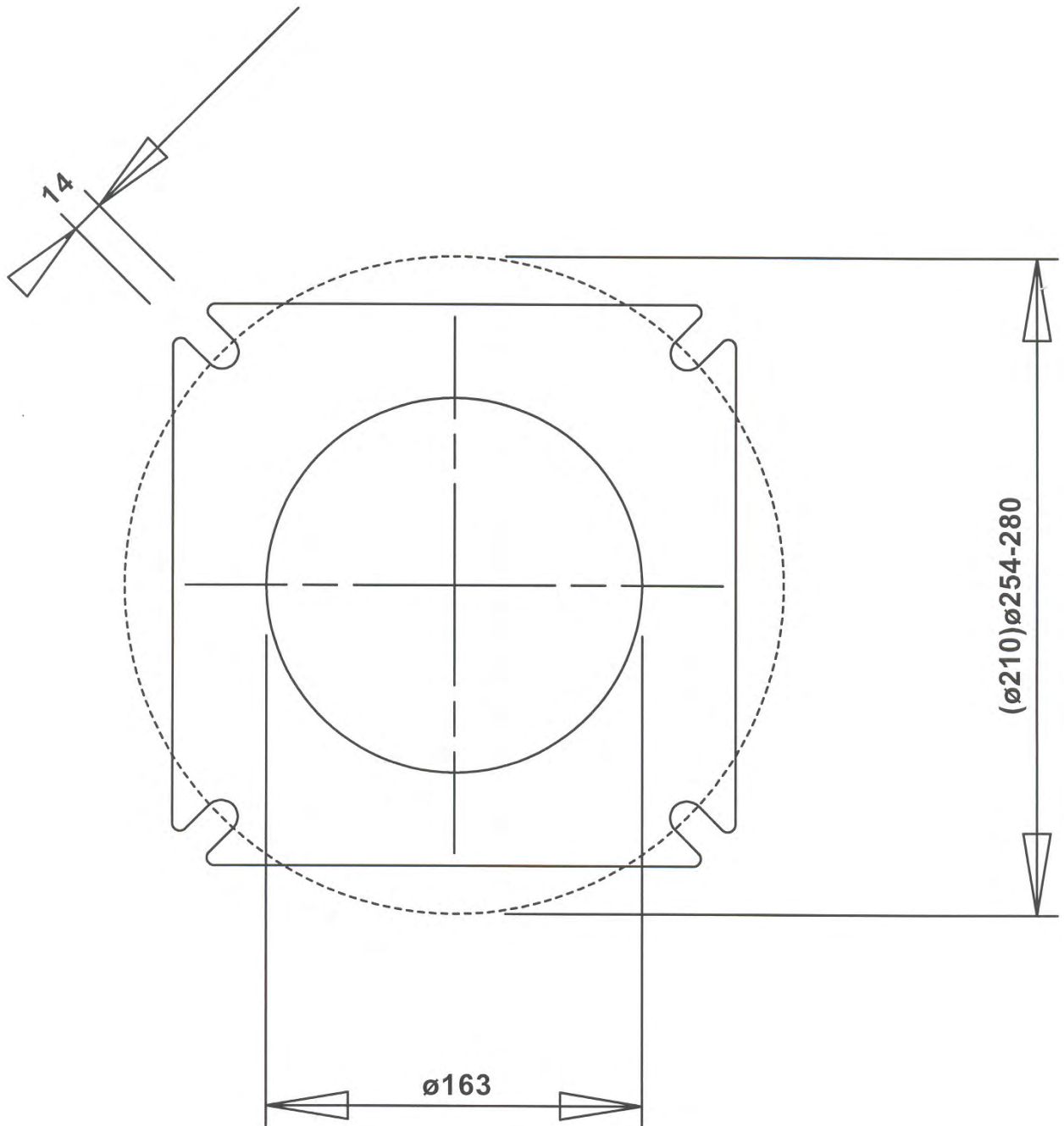

SKELETON DIAGRAMS

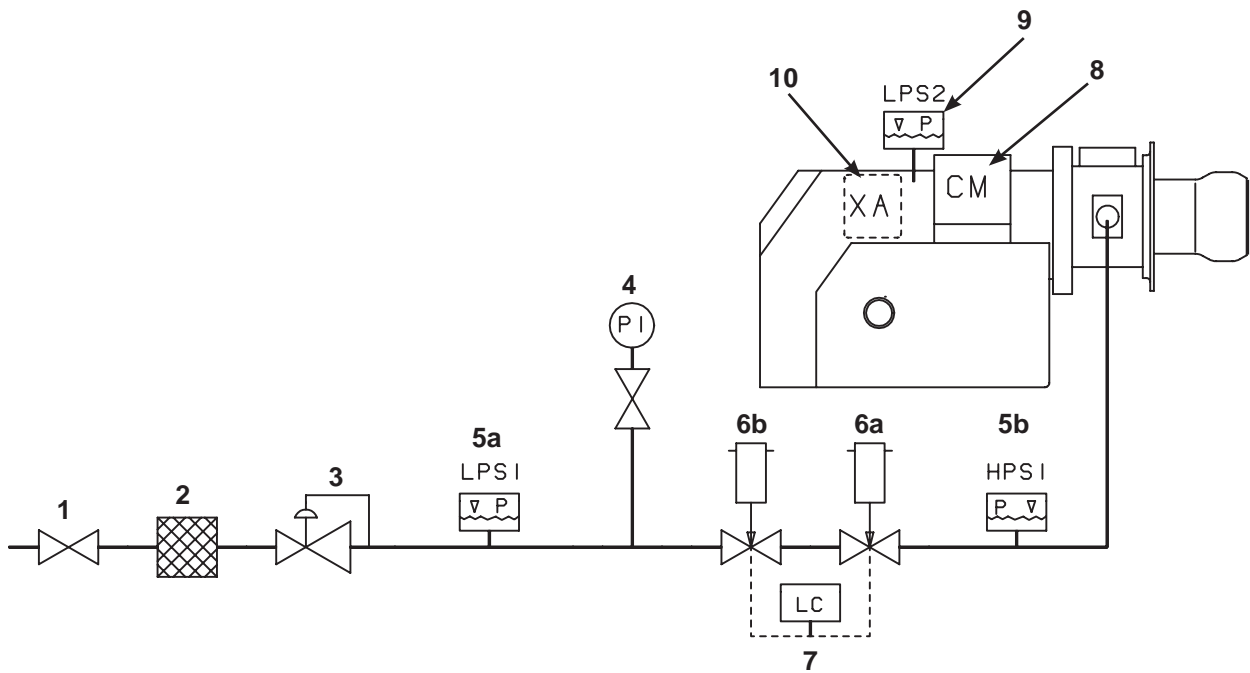

- 1. Ball valve
- 2. Filter
- 3. Governor
- 4. Pressure gauge with shut-off cock
- 5 a. Gas pressure switch, mini
- 5 b. Gas pressure switch, maxi

- 6 a. When modulating operation is required this valve is equipped with controls for variable opening.
- 6 b. Safety valve
- ¹⁾7. Valve proving system
- 8. Air damper motor
- 9. Air pressure switch
- 10. Gas burner control Pos.

- 5b, 7: Components not required according to EN 676.
- ¹⁾ Required over 1200 kW according to EN 676.



When Bio gas is used, Bentone shall always be contacted.

MOUNTING OF THE BURNER

Fit the burner to the boiler by means of 4 bolts M12. For flange and bolt dimensions see technical data.

If for some reason you want to separate the burner from the gas flange with burner head and valve package you can do so.

Do like this:

- Remove the cover of the fan housing.
- Loosen the nut D of the gas assembly package.
- Loosen the electric cables to the valve package.
- Loosen the screws B on both sides.
- Loosen the stop bolt C on the pull rods.
- Loosen the ignition cable and the ionisation cable from the gas assembly.
- Pull out the burner on the pull rods and put it in a suitable place.

When the burner head and the gas flange have been fitted to the boiler it is easy to lift up the burner to where it belongs.

Inspection of gas assembly

If the gas assembly needs to be inspected the pull rods are very useful.

Do like this:

- Remove the cover of the fan housing.
- Loosen the nut D of the gas assembly package.
- Loosen ignition cable and ionisation cable of gas assembly.
- Loosen the screw A on both sides.
- Pull out the burner on the pull rods.
- Loosen the screws B on the gas flange.
- Withdraw the gas assembly.

Ensure that the O-ring between the gas assembly and the gas flange will be in the correct position when the gas assembly is fitted again.

Adjustment of the position of the shrouded disc in the blast tube

Sometimes it is necessary to adjust the position of the shrouded disc in the blast tube. This can be done with the screw E (can be adjusted when the burner is in operation). If you turn the screw to the left the shrouded disc will move forward (+), to the right it will move backward.

SERVICE POSITION

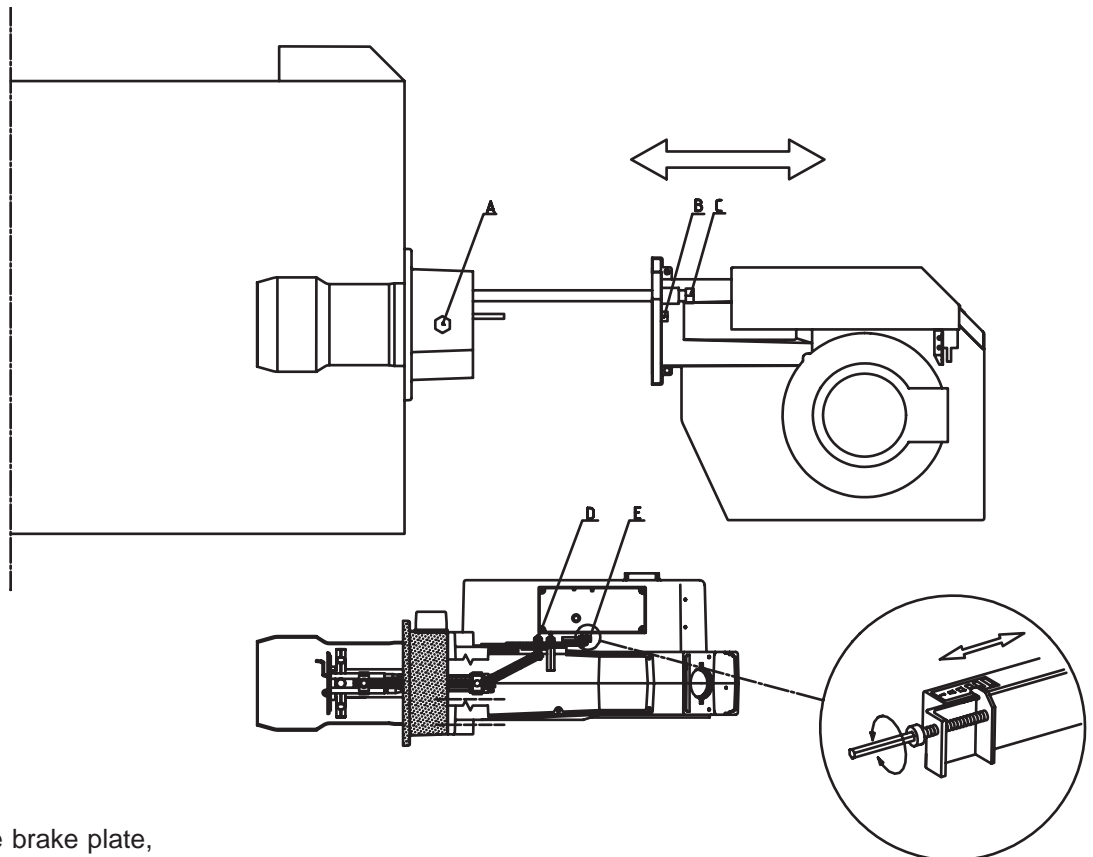

NOTE!

For maintenance of the brake plate, nozzles, electrodes etc, when using a long design of the burner tube, you have to **remove the nozzle assembly from the connecting pipe and move the assembly backwards** in the fan housing (from the boiler).

ELECTRIC EQUIPMENT

Gas burner control: LMG22/LME22 Wiring diagram

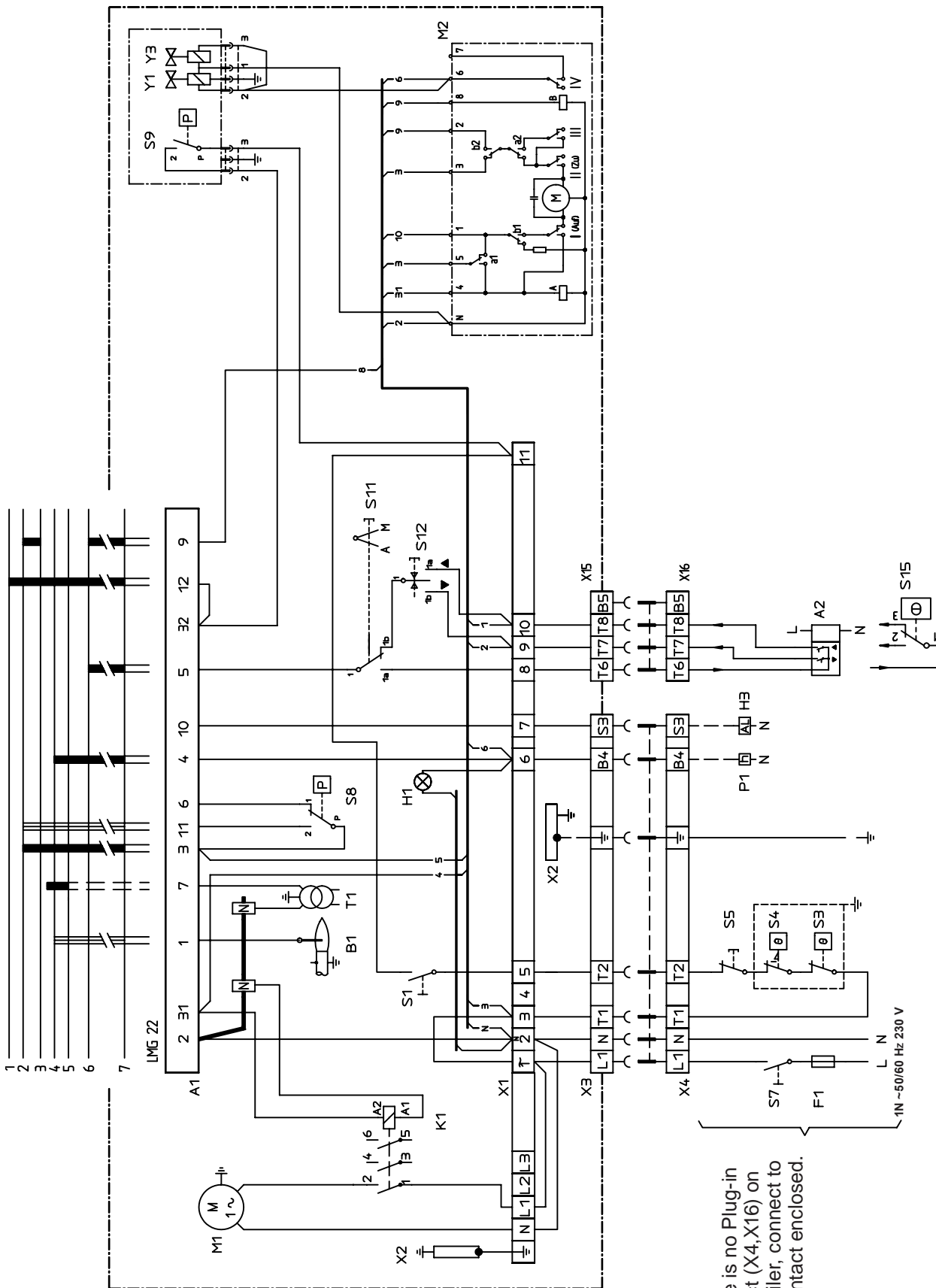

If there is no Plug-in contact (X4, X16) on the boiler, connect to the contact enclosed.

ELECTRIC EQUIPMENT

Gas burner control: LGB22/LMG22/LME22

List of components

A1	Gas burner control	S7	Main switch
A2	Power control	S8	Air pressure switch
B1	Ionization electrode	S9	Gas pressure switch
F1	Operating fuse	S11	Change-over switch, Aut.-Man.
H1	Operating lamp	S12	Change-over switch, Increase-Decrease
H3	Alarm signal 230 V	S15	Control thermostat, 3-pole (only for 2-stage sliding)
K1	Contact	T1	Ignition transformer
M1	Burner motor	X1	Connection terminal board
M2	Damper Motor, L&S SQN75.624.A21B	X2	Earth terminal
P1	Time meter, total operating time	X3	Plug-in contact, burner
S1	Operating switch	X4	Plug-in contact, boiler
S3	Control thermostat	X15	Plug-in contact, power controller, burner
S4	Temperature limiter	X16	Plug-in contact, power controller
S5	Micro switch for hinged door	Y1	Gas solenoid valve 1
		Y2	Gas solenoid valve 2

Mains connection in accordance with local regulations.

Function

1. Operating switch ON-Thermostat ON-Gas pressure switch ON-Air damper closed.

A control is made that the air pressure switch does not indicate fan pressure. Then the burner motor starts.

2. Air damper motor opens.

The air damper motor opens the damper to max position. A control is made that the air pressure switch indicates sufficient fan pressure.

3. Air damper motor closes.

The air damper motor closes to min load position. Then the ignition spark is formed.

4. Main and safety valves open

The gas is ignited. The ionization electrode indicates a flame.

5. The safety time expires.

The ignition spark goes out. The safety time expires. If there is no flame or if for some reason the flame disappears after this time limit, the burner control locks out.

6. Operating position.

The burner is in operating position and can now change over to the capacity controlled by the regulator.

7. Stop.

The operation of the burner can now be interrupted by means of the operating switch or the thermostat.

• The control locks out.

The red lamp in the control is lit. Restart the burner by pressing the reset button.

ELECTRIC EQUIPMENT

Control diagnosis under fault conditions and lockout indication

Gas burner control: LMG ...

Diagnosis of cause of fault

After lockout, the red fault LED is steady on. For reading the cause of fault, refer to the blink code given in the following table:

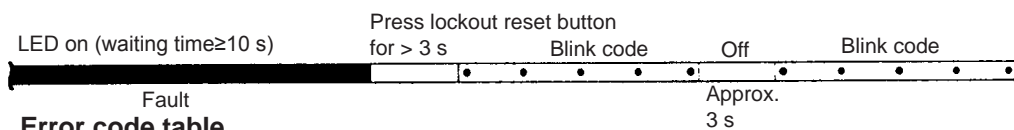
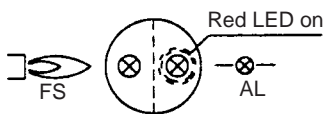

Error code table

Blink code	Possible cause
2 x ••	<ul style="list-style-type: none"> No establishment of flame at the end of «TSA» – Fault or soiled detector electrode – Fault or soiled fuel valves – Poor adjustment of burner
3 x •••	<ul style="list-style-type: none"> Air pressure monitor does not close – «LP» faulty – «LP» incorrectly adjusted – Fan motor does not run
4 x ••••	<ul style="list-style-type: none"> Air pressure monitor does not open or extraneous light on burner startup – «LP» faulty – «LP» incorrectly adjusted
5 x •••••	<ul style="list-style-type: none"> Extraneous light during pre-purging – Or internal device fault
7 x ••••••	<ul style="list-style-type: none"> Loss of flame during operation – Poor adjustment of burner – Faulty or soiled fuel valves – Short-circuit between detector electrode and ground
8...17 x ••••••• ••••••• •••••••	<ul style="list-style-type: none"> Free
18 x •••••••• ••••••••	<ul style="list-style-type: none"> Air pressure monitor opens during pre-purging or operation – «LP» correctly adjusted – Four times loss of flame during operation (LMG25)
19 x •••••••• ••••••••	<ul style="list-style-type: none"> Faulty output contact – Wiring error – External power supply on output terminal
20 x •••••••• ••••••••	<ul style="list-style-type: none"> Internal device fault

During the time the cause of the fault is diagnosed, the control outputs are deactivated.

- The burner remains shut down
 - Exception: fault status signal «AL» at terminal 10
- The burner is switched on only after a reset is made.
- Press lockout reset button for 0.5...3 seconds

Connecting signal amplifier

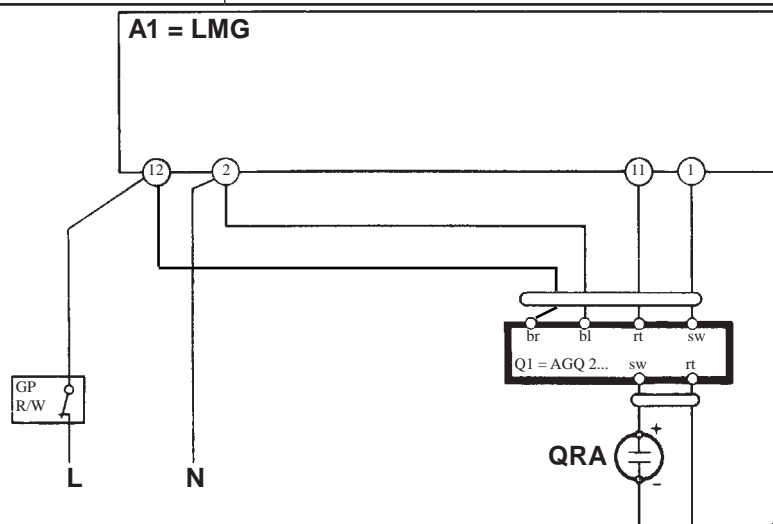

ELECTRIC EQUIPMENT

Control diagnosis under fault conditions and lockout indication

Gas burner control: LME....

Colour codes

Colour code table for multi-coloured signal lamps (Light diodes)		
Status	Colour codes	Colours
Waiting time «tw», other waiting times	○.....	Off
Ignition phase, ignition checked	•○ •○ •○ •○ •○ •	Flashing yellow
Normal operation	□.....	Green
Operation, poor flame signal	□○□○□○□○□○□○	Flashing green
Prohibited flame signal during start up	□▲□▲□▲□▲□▲□▲	Green-Red
Undervoltage	●▲●▲●▲●▲●▲●▲	Yellow-Red
Disruption, alarm	▲.....	Red
Flashing code for fault codes	▲○ ▲○ ▲○ ▲○ ▲○	Flashing red
Interface diagnostics	▲▲▲▲▲▲▲▲▲▲	Red flickering

..... Continuous ▲ Red
 ○ Off ● Yellow
 □ Green

Diagnostics alarm trigger

The red alarm signal lamp lights continuously after the alarm is disconnected. Diagnostics for alarm triggers can be read as specified by the following sequence:

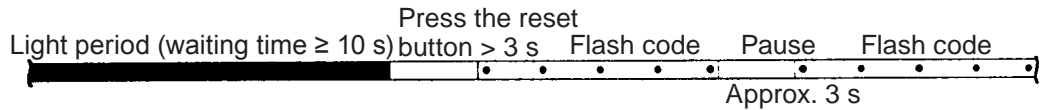
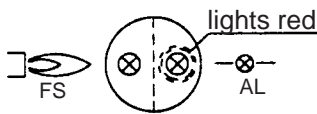

Limit on start attempts

LME 11 ... limits the number of start attempts if the flame does not ignite on start-up or goes out during operation. LME 11 ... permits a maximum of three start attempts if the start cycle is uninterrupted.

ELECTRIC EQUIPMENT

Control diagnosis under fault conditions and lockout indication

Gas burner control: LME...

Alarm control table

Red flashing code on signal lamp (LED)	Possible causes
Flashing 2 x ••	No flame at End of «TSA» – Defective or obscured flame monitor – Defective or obscured fuel valves – Poor burner installation – Defective ignition unit
Flashing 3 x •••	«LP» defective – No air monitor signal after «t10» – «LP» is welded in the open position
Flashing 4 x ••••	Prohibited flame signal during start up
Flashing 5 x •••••	Time out «LP» – «LP» is welded in the closed position
Flashing 6 x ••••••	Free
Flashing 7 x •••••••	Too many loss of flame during operation – Poor burner installation – Defective or obscured fuel valves – Defective or obscured flame monitor
Flashing 8 x ••••••••	Free
Flashing 9 x •••••••••	Free
Flashing 10 x ••••••••••	Connections fault or internal fault, outgoing contacts or other fault
Flashing 14 x •••••••••• •••••	CPI contact not closed

During alarm trigger diagnostics, control outputs are to be disconnected from all power.

- The burner is disconnected
- Exception, the «AL» alarm signal at connection block 10
The burner is only to be reconnected after it is reset
- Press the reset button 0.5...3 s

Interface diagnostics

To switch to interface mode, hold the reset button depressed for more than 3 s. To return to normal mode, hold the reset button depressed for more than 3 s. If the firing unit is in the alarm mode, it is reset by pressing the reset button 0.5...3 s.

Connecting signal amplifier

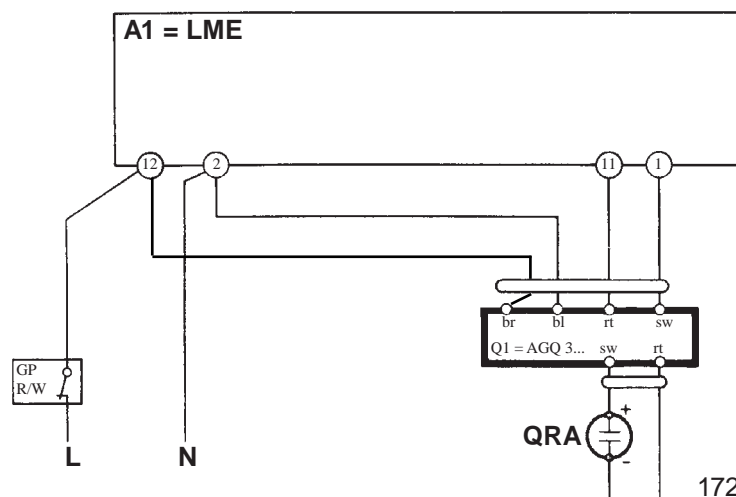

MEASURES AND CHECKS BEFORE START-UP,

2-STAGE- OR MODULATING BURNERS

General rules

Care should be taken by the installer to ensure that no electrical cables or fuel/gas pipes are trapped or damaged during installation or service/maintenance.

Inner assembly

Ensure that the ignition and ionisation electrodes are correctly adjusted. The sketch shows the correct measurements.

Gas quality

Ensure that the burner head is meant for the gas quality to be used (see fig.)

Venting

The gas line is vented by loosening the screw on the test nipple for the inlet pressure. Connect a plastic hose and conduct the gas into the open. **After having vented the gas line tighten the screw again.**

Leakage control

When making a leakage control of the gas supply system the solenoid valve should be closed. Connect a pressure gauge to the test nipple Pa, see fig. The test pressure in the system should be 1,5x max. inlet pressure or min. 150 mbar. If any leakage, locate the source by means of soapy water or a leak location spray. After tightening repeat the test.

Electric function test:

Ensure that phase and neutral are not reversed. The gas shut-off cock should be closed. To prevent the gas pressure switch from locking out it should be linked temporarily.

After the main switch has been switched on and the thermostats have been adjusted the pre-purging period begins (30-35sec.). At the end of this period the pre-ignition period starts (0,5-2,5 sec. dependent on the design of the gas control). The gas valve is energized and opens and flame is established. At the end of the safety time (2-3 sec.) the gas control locks out. The solenoid valve and the motor will be "dead". Remove the link from the gas pressure switch after the test is finished.

Note on 2-stage and modulating burners that during the pre-purging period the damper opens to the set value for air on stage 2 and just before the end of the pre-purging period it goes down to the air setting for stage 1. On some burners under 350kW the pre-purging mainly takes place with the air damper set for stage 1.

NOTE! Applies only to gas burner control LFL1.

When using LPG (Propane) the burner should be connected for post-purge. Move connection to terminal 6 to terminal 7 in the base of LFL1.

Leakage control

MultiBloc

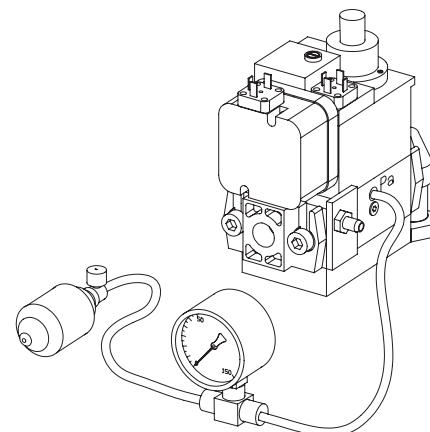

Gas train

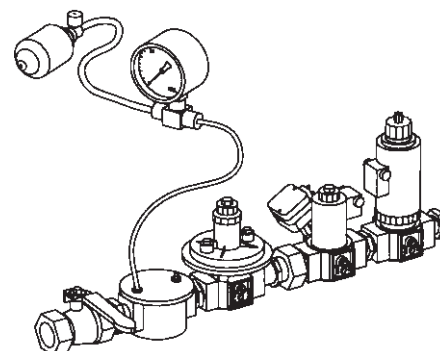

MEASURES AND CHECKS BEFORE START-UP

Inner assembly
Town gas

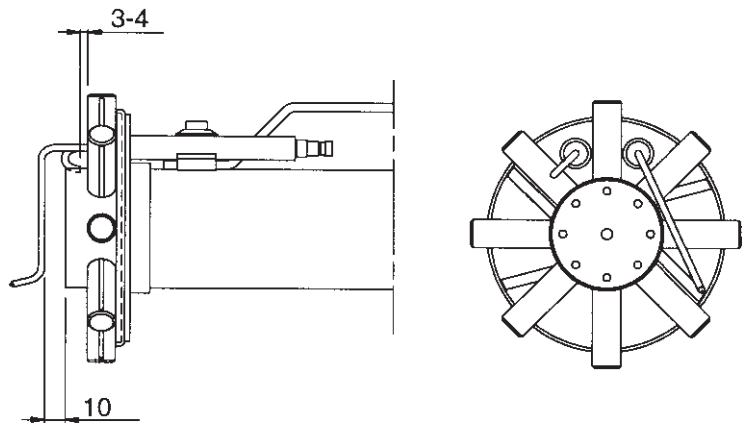

Inner assembly
Natural gas, LPG

Propan

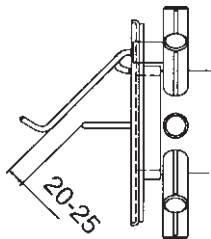

Natural gas

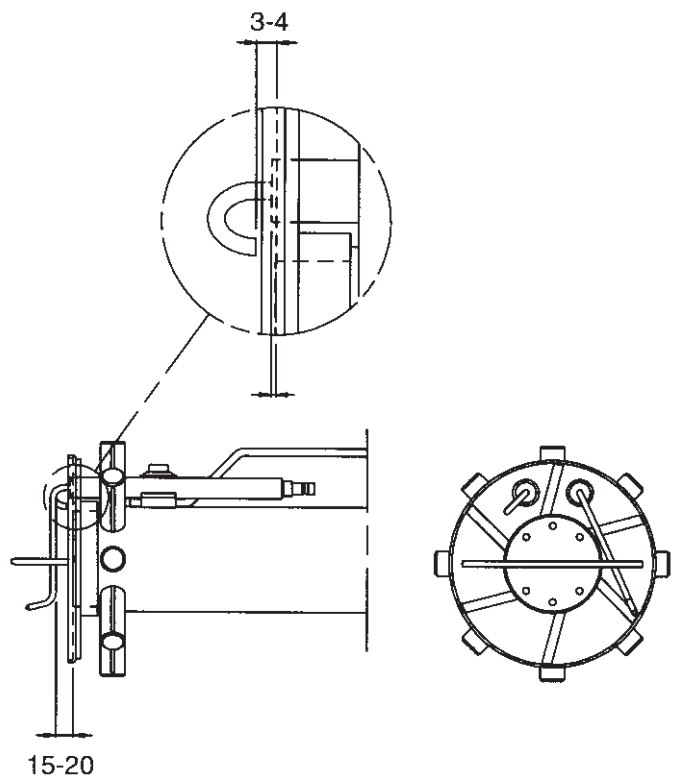

Inner assembly
Biogas ((UV-detector)

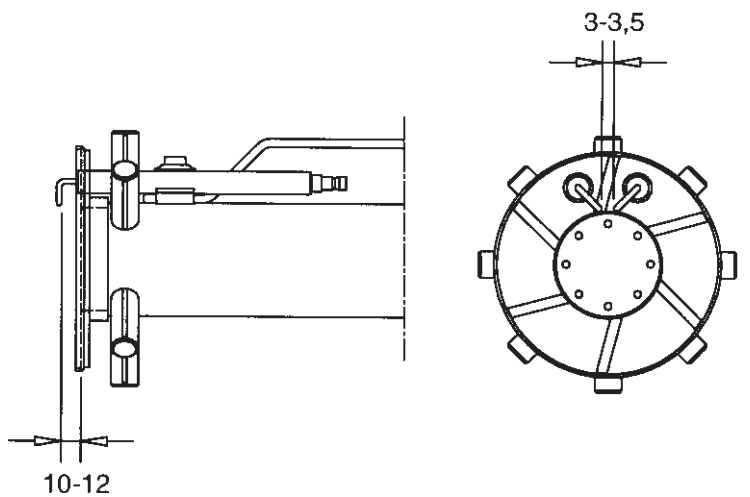

DETERMINATION OF GAS VOLUME FOR THE INSTALLATION

Specifications on natural gas, town gas and bio gas vary. For more exact information please contact the gas distributor.

Gas quality	Net calorific value		
	kWh/Nm ³	kJ/Nm ³	kcal/Nm ³
Natural gas	10,3	37 144	8 865
Propane	26,0	93 647	22 350
Butane	34,3	123 571	29 492
Town gas	4,9	17 653	4 213
Bio gas	7,0	25 219	6 019

Example how to calculate the gas volume (natural gas)

V = Gas volume Nm³/h

Q = Boiler output 120 kW

H_u = Calorific value of the gas A. 37 144 kJ/Nm³, B. 10.3 kWh/Nm³

η = Expected efficiency 90%

$$\text{Ex. A } v = \frac{Q \cdot 3\,600}{H_u \cdot \eta} = \frac{120 \cdot 3\,600}{37\,144 \cdot 0,90} \approx 12,9 \text{ Nm}^3/\text{h}$$

$$\text{Ex. B } v = \frac{120}{10,3 \cdot 0,90} \approx 12,9 \text{ Nm}^3/\text{h}$$

If the barometer height, pressure and temperature of the gas deviate very much from the normal values this must be taken into account as follows:

$$f = \frac{273+t}{273} \cdot \frac{1013,25}{B+P_u}$$

t = Temperature of the gas at the gas meter (15°C)

B = Barometer height (945 mbar)

P_u = Pressure of the gas at the gas meter (15,0 mbar)

$$f = \frac{273+15}{273} \cdot \frac{1013,25}{945+15}$$

$$f = 11,1$$

The gas volume read on the gas meter actually reads 1,11 · 12,9 = 14,4 m³/h.

DUNGS COMBI BLOC WITH RATIO ADJUSTMENT MB-VEF BO1, 412 - 425

View

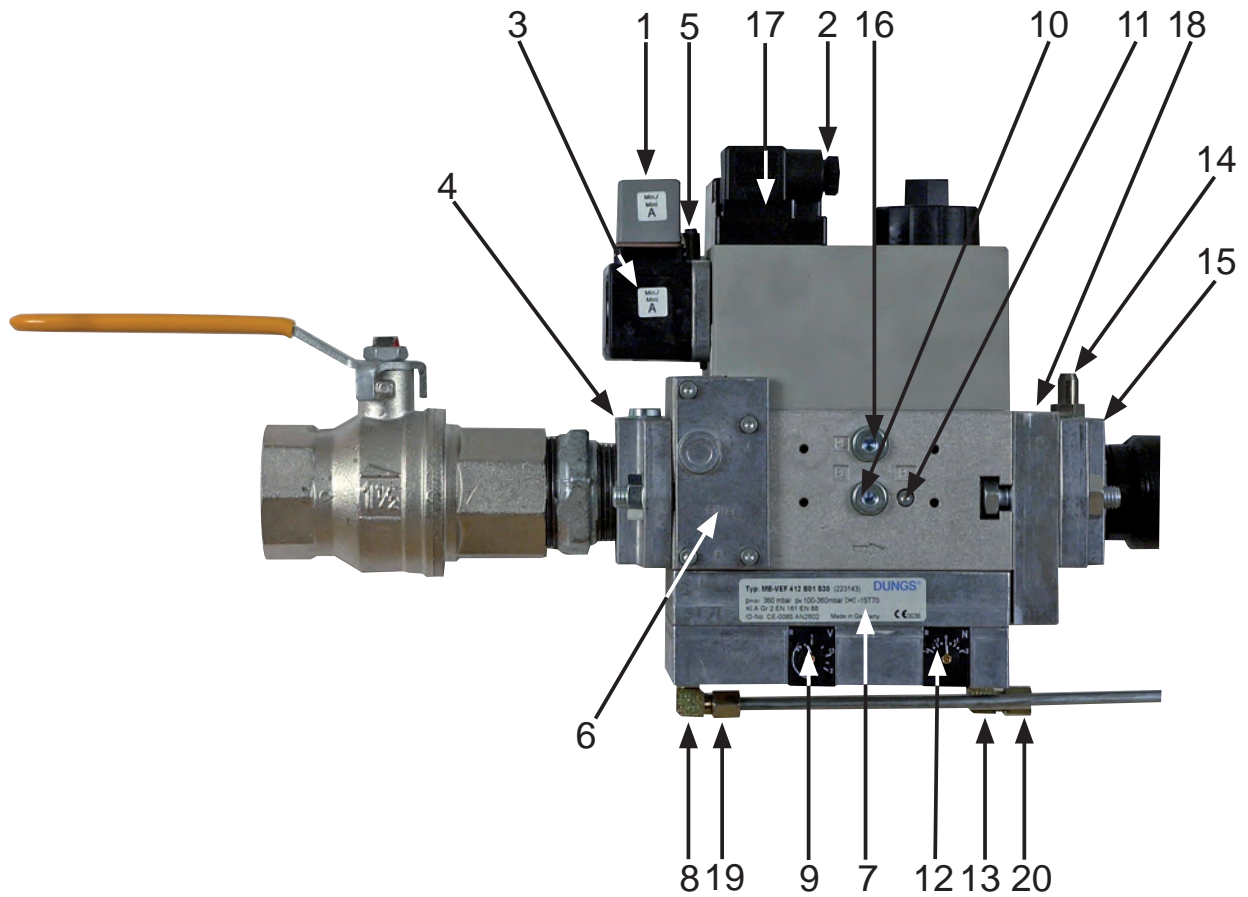

1. Electrical connection gas pressure switch mini
2. Electrical connection gas valve
3. Pressure switch mini
4. Flange connection inlet
5. Test point connection 1/8" before V_1
6. Filter (on Multi-Bloc 425 external filter)
7. Data plate
8. Connection 1/8" P_L
9. Adjustment screw V for ratio $P_{Br} : P_L$ (max. load)
10. Test point connection 1/8" before V_1 (before governor)
11. Connection M4 for measurement of burner pressure after V_2
12. Adjustment screw for zero point adjustment N (min. load)
13. Test point connection 1/8" P_F
14. Test point connection 1/8" P_{Br} (after V_2 burner)
15. Flange connection, outlet
16. Test point connection 1/8" P_a before V_2 (after governor)
17. Indication of V_1 and V_2 in operation (not standard)
18. Impulse flange P_{Br} (gas pressure)
19. Impulse line P_L (air pressure)
20. Impulse line (fire room)

It is possible to connect a leakage control VPS 504 and a gas pressure switch maxi.

TECHNICAL DATA WITH RATIO ADJUSTMENT

- Max inlet pressure 360 mbar
- Valves V_1+V_2 class A group 2 in accordance with EN 161
- Governor class A group 2 in accordance with EN88
- Ratio $V P_{Br}:P_L$ 0,75:1-3:1
- Filter according to DIN 3386
- Ambient temperature -15°C - $+70^{\circ}\text{C}$
- Protection standard type IP54 (according to IEC 529, DIN 40050)
- Gas family 1 +2 +3
- Outlet pressure 0,5 - 100 mbar
- Zero point adjustment $N \pm 2$ mbar
- Pressure switch DIN3398 TI
- Fan pressure P_L 0,4-100 mbar
- Fire room pressure P_F -2 -+5mbar
- Burner pressure P_{Br} 0,5 - 100 mbar

Mounting instruction - impulse lines P_L , P_F and P_{Br}

- Impulse lines should preferably be made of steel. Inside diameter $>\varnothing$ 4 mm (steel tube \varnothing 6/4)
- For P_L other material can be used.
- Impulse lines P_L and P_{Br} are ready from factory
- Impulse lines shall be mounted in such a way that no condensate can flow back into the multibloc. This is especially important when P_F is concerned.
- Impulse lines shall be mounted in such a way that they are protected against rupture and damage.
- Impulse lines shall be as short as possible

Adjustment possibilities

Adjustment range



Effective burner pressure

$$\Delta P_{Br} = P_{Br} - P_F$$



Effective fan pressure

$$\Delta P_L = P_L - P_F$$

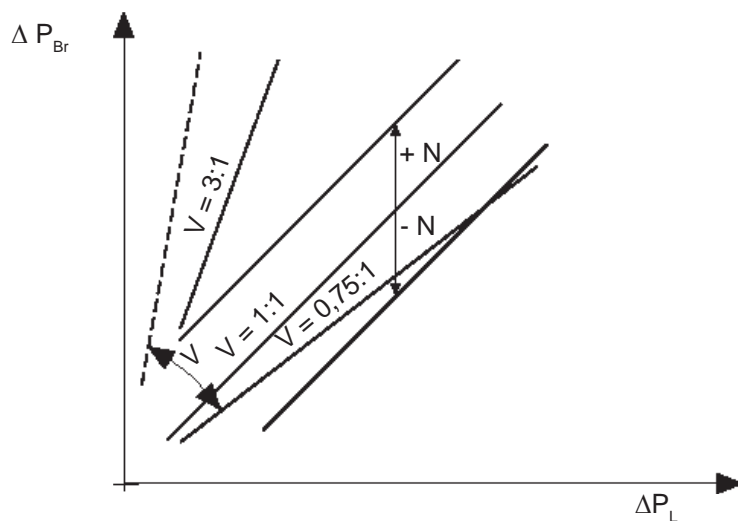

Adjustment range

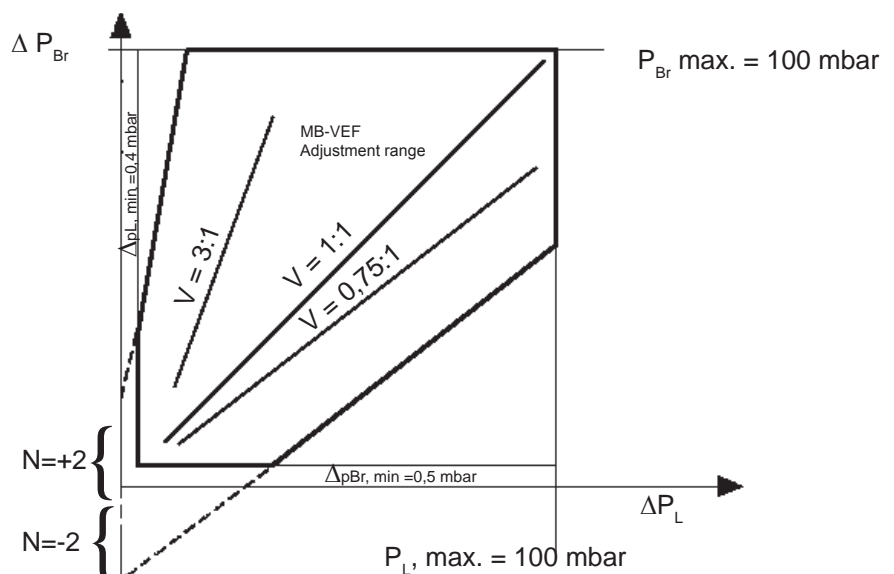

ADJUSTMENT OF GAS FLOW

Damper motor, air volume

Adjust the orange cam for min. load
(about 5-10 on scale)

Adjust the red cam for max. load
(90°)

The blue cam is factory set for
closed position during standstill

The black cam has no function at
modulating operation

Gas valve (black)

Max. load (red)

Min. load (orange)

Closed damper (blue)

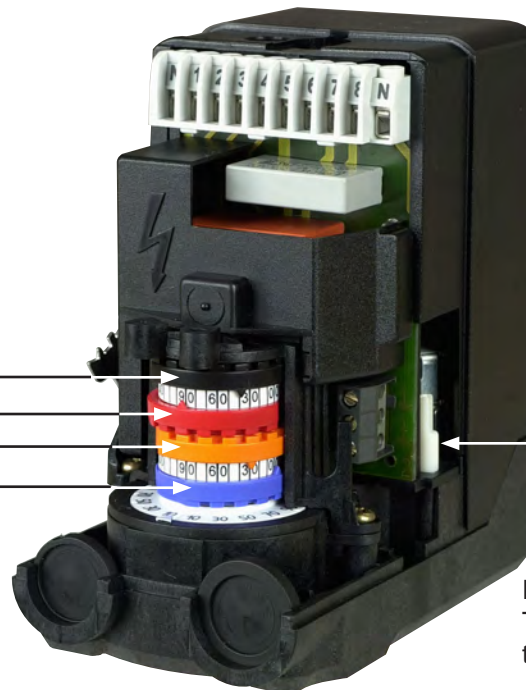

Releasing button **N.B.**
The upper position is
the standard position

Adjustment of gas flow

- Before the burner starts vent the lines to make sure that there is gas available at the multibloc
- Use an allen key size 2,5 mm for adjusting N and V.
- Connect a pressure gauge for measuring P_{br} (advisable to find out if the valves are open)
- Set the switch in position MAN.
- Set the gas pressure switch min. and air pressure switch on min. adjustment. Set the gas pressure switch max, if any, on max. adjustment.
- Start the burner, observe the pressure gauge, if no flame is established and the pressure gauge needle does not flicker, increase N. When the flame is established adjust the gas flow by means of the screw N. Use a flue gas instrument.
- Change over to max. load, press the switch "increase"
- Adjust the gas flow with V and check at the same time the combustion values.
- Go back to min. load and check the combustion value. Adjust if necessary.
- If necessary repeat the controls of the adjustment made on min. (N) and max. load(V).
- The desired gas flow on min. and max. has now been adjusted by changing the orange and the red cams. Check the gas flow on the gas meter available on the installation.
- Note! Do not forget to set the air and gas pressure switches after the adjustment, see special instructions.

Releasing button

By pressing the button and snapping it down, the motor will be released and the damper can easily be turned. This function facilitates an exchange of damper motor.

GENERAL INSTRUCTIONS

Adjustment of burner

The burner is from the factory pre-set to an average value that must then be adjusted to the boiler in question.

All burner adjustments must be made in accordance with boiler manufacturers instructions. These must include the checking of flue gas temperatures, average water temperature and CO₂ or O₂ concentration.

General instructions

The installation of the gas burner must be carried out in accordance with current regulations and standards. The installers of gas burners should therefore be acquainted with all regulations and ensure that the installation complies with the requirements. The installation, mounting and adjustment should be made with the greatest care and only the correct gas should be used.

Operating instructions

The operating instructions accompanying the burner should be left in a prominent position in the boiler room.

Instructions

The user should be thoroughly instructed in the function of the gas burner and the whole installation. The supplier must instruct the user.

Inspection and maintenance

Daily inspection is advisable.

Start up

After the burner has been fitted to the boiler and the electric connection, the leakage control, the venting and the electric function test have been carried out, the burner will be ready for start-up.

However, study the sections dealing with adjustments of multi-bloc, combustion air and combustion head. Open the ball valve and switch on the main switch. If the burner starts the actual adjustment can be made.

Adjustment of burner head

The burner is equipped with an adjustment device changing the position of the brake plate in the burner head. This is used to adjust the correct pressure drop over the combustion device in order to obtain a good pulsation free combustion.

Which position to use depends on input and overpressure in the boiler.

A general rule is that the lower capacity the smaller the opening between brake plate and combustion device.

Commissioning of installation

Control of the combustion. The combustion quality is checked by means of a flue gas analysis device. Adjust the burner to appr. 20% excess air in accordance with the table. Check the flue gas temperature. Calculate the efficiency. Check also the actual gas volume on the gas meter so that the correct input is achieved.

Service

Service should only be carried out by qualified personnel. Replacement parts should be of the same make and approved by the same authorities as the original. If the burner is converted to fire another gas quality it must be re-commissioned. If town gas is to be fired the combustion head must be converted and the gas train adjusted to suit (e.g. a larger gas armature or a different spring in the governor may be required).

Gas quality	CO ₂ % lambda 1,2	O ₂ %	max. CO ₂ %
Natural gas	10,0	3,5	11,9
LPG	11,5	3,5	13,9

GENERAL INSTRUCTION

Flame monitoring and measurement of ionisation current

The burner is monitored according to the ionisation principle. Check the ionisation current on start-up and on each service call.

The reason for a low ionisation current may be leaking currents, bad connection to earth, dirt or a faulty position of the flame electrode in the burner head. Sometimes also a faulty gas/air mixture may cause too weak a ionisation current.

The ionisation current is measured by means of a microampere meter (μA) connected in series with the flame electrode and the gas burner control.

Connect the μA -meter, see figure. Min. required ionisation current according to table. In practice this current must be considerably higher, preferably more than $10 \mu\text{A}$. All the gas burners are equipped with a ionisation cable that can be slit which facilitates the connection of the μA -device.

Gas pressure switches:

Adjustment range:
 2,5-50 mbar GW 50
 5-150 mbar GW 150

Adjustment of min. gas pressure switch

The min. pressure switch should react if the gas pressure is too low and prevent the burner from starting. Too low a gas pressure during operation should stop the burner. The burner may start again when the rated pressure has been reached.

Remove the protective cover. Connect a pressure gauge for measuring the rated pressure. Decide on pressure at which the gas switch should switch off. Set this pressure by means of the valve. Carefully turn the knob (see figure) until the gas pressure switch switches off. The value shown on the scale should then approximately correspond with the value shown on the pressure gauge. Tolerance on scale appr. $\pm 15 \%$. Open the ball valve.

Adjustment of max. gas pressure switch

The burner is equipped with a max. gas pressure switch only on request. It should stop the burner if the gas pressure exceeds the set value. The burner can then only be re-started manually (gas burner control or overpressure switch).

Remove the protective cover. Connect a pressure gauge for measuring the rated gas pressure. Decide on pressure at which the gas pressure switch should switch off. Turn the adjustment knob to this value. Tolerance on the scale $\pm 15\%$.

Adjustment of air pressure switch

The air pressure switch should stop the burner if the air volume is reduced.

The air proving device shall be adjusted in such a way that if there is insufficient air supply at the highest or lowest burner operating stage, the device operates before the supervised pressure is less than 80% of the pressure at the controlled stage and the CO content of the combustion products exceeds 1% by volume.

Air pressure switch:

Adjustment range ca:
 1-10 mbar LGW 10
 2,5-50 mbar LGW 50

Gas control	Connection to terminal in gas control	Min. ionisation current required
LMG	1	$2 \mu\text{A}$
LGB	1	$10 \mu\text{A}$
LFL	24	$10 \mu\text{A}$
MMI 810	2	$5 \mu\text{A}$
TMG 740-3	1	$5 \mu\text{A}$

Flame monitoring

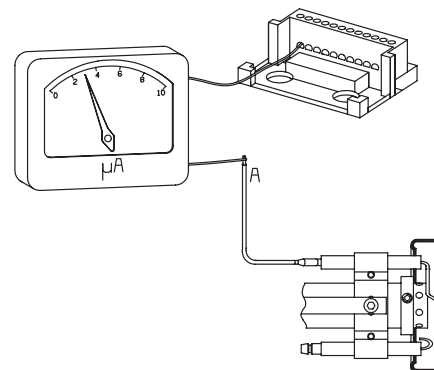

Gas pressure switch, air pressure switch

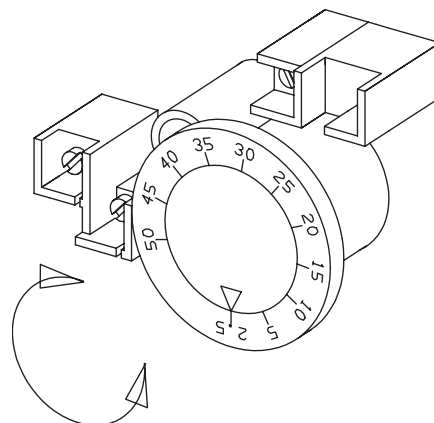

HANDING OVER OF THE INSTALLATION

- Make repeated start attempts to ensure that the adjustments function.
- Close the ball valve during operation to check that the gas switch switches off at the set value.
- Remove the hose for the air pressure switch to check that the burner locks out.
- Check that all protective covers and measurement nipples are mounted and fastened.
- Fill out necessary test reports.
- Instruct the persons in charge of the operation on the service and maintenance of the installation and what to do should any troubles occur.
- Inspection and service must only be carried out by authorized people.

Fault location, functional troubles

Trouble free operation is dependent on three factors: electricity, gas and air supply. Should there be any changes in the ratio between these three factors there is a risk of break downs. It has been proved that most break downs are caused by simple faults. Before calling the service engineer, the following should therefore be checked:

- Is the gas cock open?
- Are all fuses in order and the current switched on?
- Are the thermostats correctly set?
- Are pressostats, overheating protection etc. in operating position and not locked-out?
- Is the gas pressure sufficient?
- Is the gas burner control in start position?
- Has the gas control or the motor protector locked out? - Reset.
- Is the circulation pump in operation?
- Is there a supply of fresh air to the installation?

If integral components are of a different make from what is stated in this manual, see the enclosed loose-leaf.

FAULT LOCATION GUIDE

Gas burner

The basis for trouble free operation can only be ensured by the correct combined effect of the three factors: electricity, gas flow and combustion air. Should any of these factors change troubles may arise.

It has been proved that many troubles have rather simple causes. Before calling the serviceman the following checks should be made:

1. Are the gas cocks of the installation open?
2. Are the fuses in order and the current switched on?
3. Are the controls (room thermostat, boiler thermostat etc.) correctly adjusted?
4. Is the gas pressure to the burner sufficient?
5. Is the gas relay of the burner ready for start and not locked out?
6. Is the air supply to the burner sufficient?

To facilitate fault location we have drawn up a scheme showing the most frequent faults in a gas burner installation and the remedies.

CAUSE	REMEDY
The burner does not start	
No gas	Check that all gas cocks are open.
No voltage	Check fuses, thermostats and electrical connections
The burner motor fails to start	The thermal protection has locked out. Motor defective.
The gas relay is defective	Replace
Burner motor is running but no ignition after the prepurge time has elapsed	
No voltage on the terminals	Check the contact. Replace faulty relay
The ignition electrodes in contact with each other or with earth	Adjust
The porcelain of the electrodes is broken	Replace the electrodes

CAUSE

REMEDY

The cable shoes have bad contact

Improve the contact

The ignition cables are damaged

Replace

The ignition transformer is damaged, no voltage on the secondary side

Replace the transformer

The ignition cable and the ionisation cable have been transposed.

Change

No flame establishment in spite of a trouble free start

The gas solenoid valve defective

Replace

The gas solenoid valve does not open in spite of its obtaining voltage

Replace coil or the whole valve if necessary.

No voltage to the solenoid valve

Check the contact

No electrical connection through the air pressure switch

Test the adjustment and the function of the air pressure switch

The starting load is not correctly adjusted

Reduce or increase the gas supply, reduce the quantity of air

Gas relay defective

Replace

Air pressure switch incorrectly adjusted or defective

Check the adjustment and readjust.

No reponse as the cams of the servomotor are not correctly adjusted or out of position.

The burner locks out after the safety time has elapsed in spite of flame establishment

No ionisation current or the UV-cell in wrong position

Adjust the ionisation electrode and the UV-cell, examine cables and connections.

The supervision part of the gas relay is defective

Replace the relay

CAUSE

REMEDY

Voltage lower than 185 V

Contact the electricity authorities.

The ignition electrodes are disturbing the ionisation current

Adjust the ignition electrodes, repole the ignition transformer if necessary.

Bad earthing

Arrange for proper earthing.

Phase and neutral transposed

See wiring diagram and change.

The burner locks out during pre-purge

Air pressure switch defective or incorrectly adjusted

The starting load is not correctly adjusted

Reduce or increase the gas supply. Reduce the quantity of air.

The gas pressure is too low

Increase the pressure. Contact the gas supply company if necessary.

Pulsations at start

The ignition electrodes are wrongly adjusted

Readjust.

The gas pressure is too high

Check and adjust by means of a pressure gauge and a pressure adjustment valve.

The flue gas side is blocked

Check the chimney flue.

Pulsations during operation

The burner is not correctly adjusted

Readjust

The burner is dirty

Clean the burner.

Defective chimney

Check and change the dimensions if necessary.

The burner is operating correctly but locking out now and then

The ionisation current is too low

Check. Must be at least 4 μ A according to the relay manufacturer but should be 8-20 μ A.

The UV-cell is in a wrong position

Adjust.

Voltage drop at certain times

Must not drop more than 15% of the rated current. Contact the electricity authorities if necessary.

Air pressure switch defective or incorrectly adjusted

Spark-over in ignition electrodes

Replace the electrodes

CAUSE

REMEDY

The ambient temperature of the gas relay is too high

Heat insulate, max. 60° C.

The ignition spark is too weak

Check the transformer

Bad combustion

Bad draught conditions

Check the chimney

The flue gas temperature is too high

The boiler is overloaded. Reduce the quantity of gas.

The CO₂-content is too low

Check the boiler with regard to leaks. Choke the draught if it is too high.

The CO-content is too high

Excess air when using natural gas and gasoil (propane, butane)

Choke the air.

Air shortage

Open the air supply. Check the flue gas damper.

The holes in the gas nozzle are clogged

Clean.

The fresh air intake is too small

Check and enlarge.

The flame is not burning straight because the burner head is out of position

Check the burner head and readjust.

Condensation in boiler and chimney

The flow gas temperature is too low or the quantity of gas is not sufficient

Increase the flue gas temperature by increasing the gas supply. Insulate the chimney

DECLARATION OF CONFORMITY

We
(supplier's name)

ENERTECH AB

(Address)

Box 309, S-341 26 Ljungby, Sverige

declare under our sole responsibility that the product
(name, type or model, batch or serial number, possibly sources and number of items)

**BG100, BG150, BG200, STG120, STG146, BG300, BG300LN, BG400, BG400LN, BG450, BG450LN,
BG500, BG550, BG550LN, BG600, BG600LN, BG650, BG700, BG 700LN, BG800, BG800LN and BG950
all fan gas burners**

to which this declaration relates is in conformity with the following standard(s) or the normative document(s)
(title and/or number and date of issue of the standard(s) or other normative document(s))

EN 676, DIN 4788

following the provisions of Directive
(if applicable)

Gas directive 90 / 396 / EEC, EMC directive 89 / 336 / EEC och Low voltage directive 73 / 23 / EEC

Ljungby 090126

(Place and date of issue)

ENERTECH AB

Sven-Olov Lövgren



(name and signature of equivalent marking of authorized person)